

Be sure to read the manual before using the system

- This manual is the user manual of double swing handheld laser welding system
- Read the manual carefully first to ensure the correct electrical connection

BWT20

Qilin double swing handheld laser welding system user manual

V11 control box + BWT 20 welding head



Guangdong Qilin Laser Technology Co., Ltd

Address: Room 901, Building E1, SongshanLake Intelligent Valley, Yanhe North Road No.9, Liaobu Town, Dongguan City, Guangdong China

Tel.: 0755-27999931

mail:

address: www.qilinlaser.com

Copyright Statement

Guangdong Qilin Laser Technology Co., Ltd. (hereinafter referred to as Qilin Laser) reserves all powers.

— Qilin Laser has the patent copyright and intellectual property rights of this product. Without the authorization and permission of Qilin Laser, it shall not directly or indirectly copy, manufacture, process and use the product and its related parts, otherwise Qilin Laser will be investigated for relevant legal liabilities according to law.

— Qilin Laser retains the right to modify the documents included in this manual without prior notice, while retaining the right to modify any documents attached to this product.

— Users should read this manual carefully when using the products described in this article. Qilin Laser shall not bear the direct, indirect, special, incidental or corresponding losses or liabilities caused by the improper use of this manual or this product. Qilin Laser does not bear the following direct or indirect liabilities or losses:

- User shall improperly use this manual or this product
- The loss caused by the user does not follow the relevant safety operation procedures

— The loss caused by natural force makes the machine in the movement dangerous, the user has the responsibility to design an effective error handling and safety protection mechanism in the machine, and Qilin laser has no obligation or responsibility to be responsible for the incidental or corresponding losses caused thereby.

Certification statement

The CE Certification Statement

This product has passed the European Union CE (Communate Europene) safety, certification, has passed the corresponding conformity assessment procedures and the manufacturer's declaration of conformity, in accordance with the relevant EU directives.

ROHS, the certification statement

This product has been approved by the European Union legislation on restricting the use of certain Hazardous ingredients in electronic and Electrical Equipment (Restriction of Hazardous Substances) safety certification, in accordance with the relevant environmental regulations of the European Union.

FCC Certification statement

This product has been certified by the Federal Communications Commission (Federal Communications Commission) and complies with the relevant safety regulations of American electronic products.

security information

When using the system, please ensure that the operation is correct and safe. Some signs or words will be used to remind you of dangerous matters and some important information.



danger:

Represents a serious danger. In the process of use, if the operation is improper or the use method is wrong, it may lead to serious injury or even death, please users and related personnel do not operate easily, until to ensure that the operation method and the correct way of use.



warn:

Indicates that a danger exists. In the process of use, if the operation is improper or the use method is wrong, which may cause injury to the personnel, please do not operate easily, until you ensure that the operation method is correct and the use method is correct.



prudent:

Represents a product potential risk. During use, if the use method is wrong or improper operation, the product or some parts may be damaged. Please users and related personnel do not operate easily until the operation method is correct and the use method is correct.



important:

Represents an important information to note during the product. Please do not ignore this information, which provides effective operational help.



This label indicates laser radiation, which will generally be affixed to the product output of laser. Please, be careful of laser and safety when using such equipment.

Receiving goods, unpacking and inspection

The product uses shock-proof soft packaging. If the package has any external damage marks, please check the damage to the equipment and notify the carrier and the carrier of the damage in written documents.



important:

After receiving the product, please check whether the outer package is in good condition, and check whether the product is complete and all parts are intact after unpacking. If any damage is found, please contact the Qilin Laser immediately.

Remove all the goods from the packaging, and keep the packaging materials and wiring spare parts. When dismantling the package and removing the goods,

Please be careful of the goods for safety. After removing the goods, please check if the parts are complete and intact. If any missing parts or parts are damaged, please contact Qilin Laser immediately. If any obvious damage to the equipment, do not install or debug the equipment.

BWT 20 The shipping list of the user's manual is shown in the following table:
(As the product is constantly updated, the shipping list may also be adjusted.)

	component	quantity	explain
1	BWT 20 Hand-held welding torch	1	
2	The V 11 control box	1	
3	T20 wire feeder	1	apolegamy
4	7-inch LCD screen (HMI)	1	
5	The 7-inch display screen cable	1	
6	Plus or minus 15V power supply	1	
7	Plus or minus 15V power cord	1	
8	24V power cord	1	
9	Urgent stop trigger line	1	
10	7.5 m DB15 main set line	1	
11	Safety clip (with clip)	1	
12	Set of wire protection box	1	
13	Copper mouth and wire clip box	1	
14	laser goggles	1	
15	Protect the lens	5	

catalogue

Chapter 1 Overview	7
1.1 BWT 20 Qilin double swing handheld laser welding system brief introduction	8
1.2 Touch-screen installation dimensions	8
1.2.1 Touch-screen installation dimensions	8
1.2.2 Control box mounting dimensions	9
1.2.3 15V switch power supply installation size	9
Chapter 2. System Wiring	10
2.1 Control box wiring	11
2.2 Structural diagram of the gun and the pipe interface	12
2.3 Power joggle	14
2.4 human-computer interface HMI	16
2.5 Double-swing handheld laser welding head connector	16
2.6 Fan interface introduction	17
2.7 Control interface of the wire feeder	17
2.8 Description of the wire feeder button	17
2.9 Laser device control interface	14
2.10 Gas control, air pressure detection interface	18
2.11 Dial switch	19
Chapter 3 HMI Introduction	24
3.1 Introduction to HMI function and operation	
Introduction of the function and operation of the main interface	25
3.1.2 Set the interface function and operation introduction	25
3.1.3 Introduction of function of small display screen of gun head	
Chapter 3: Precautions	30
Qilin laser technical support and service scope	31

Chapter 1 summary

The main contents of this section are:

- Introduction to the double-swing handheld laser welding system
- Product installation size drawing

1.1 Qilin double swing handheld laser welding system brief introduction

Qilin double swing handheld laser welding system is a control system developed for fiber laser welding. Double vibration lens motor control, there are seven swing modes: point, line, ring, oval, triangle, eight characters, semicircle. High-speed digital motor swing design, circulation waterway design, fast cooling optical cavity, ergonomic design, high-end chip, a variety of safety protection measures and other functions and features.

1.2 Installation size of the touch screen

1.2.1 Touch screen installation dimensions are shown below:

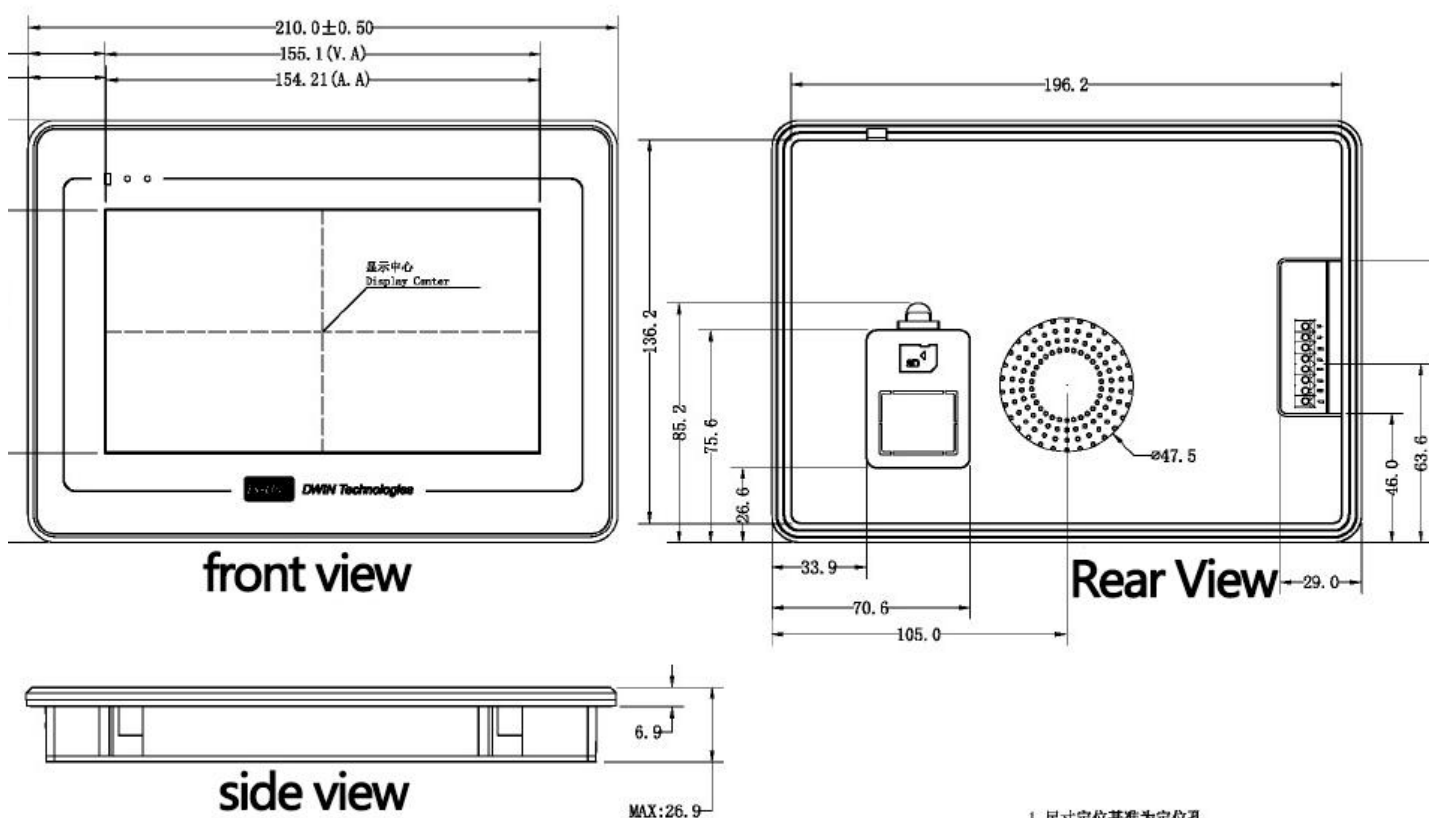

1. 尺寸定位基准为定位孔
Location hole is used as position reference.
 2. 未标注公差为 $\pm 0.3\text{mm}$
Unmarked Tolerance is $\pm 0.3\text{mm}$
- 注: 虚线标注为有效显示区域
Active area is marked in Dash lines

Chapter 2 System wiring

The main contents of this section are:

- Control box wiring
- Structural diagram of the gun and the pipe interface
- Power interface
- Human machine interface HMI
- Double-swing handheld laser welding head connector
- Lead trigger line
- Fan interface introduction
- Control interface of the wire feeder
- Description of wire feeder
- Laser device control interface
- Gas control, air pressure detection interface
- Alarm signal interface
- Warning lamp interface
- Dial switch

2.1 Wiring of the control box

The following figure shows the wiring diagram of the whole system. The system wiring can refer to the schematic diagram and refer to the relevant chapter for detailed interface definition.

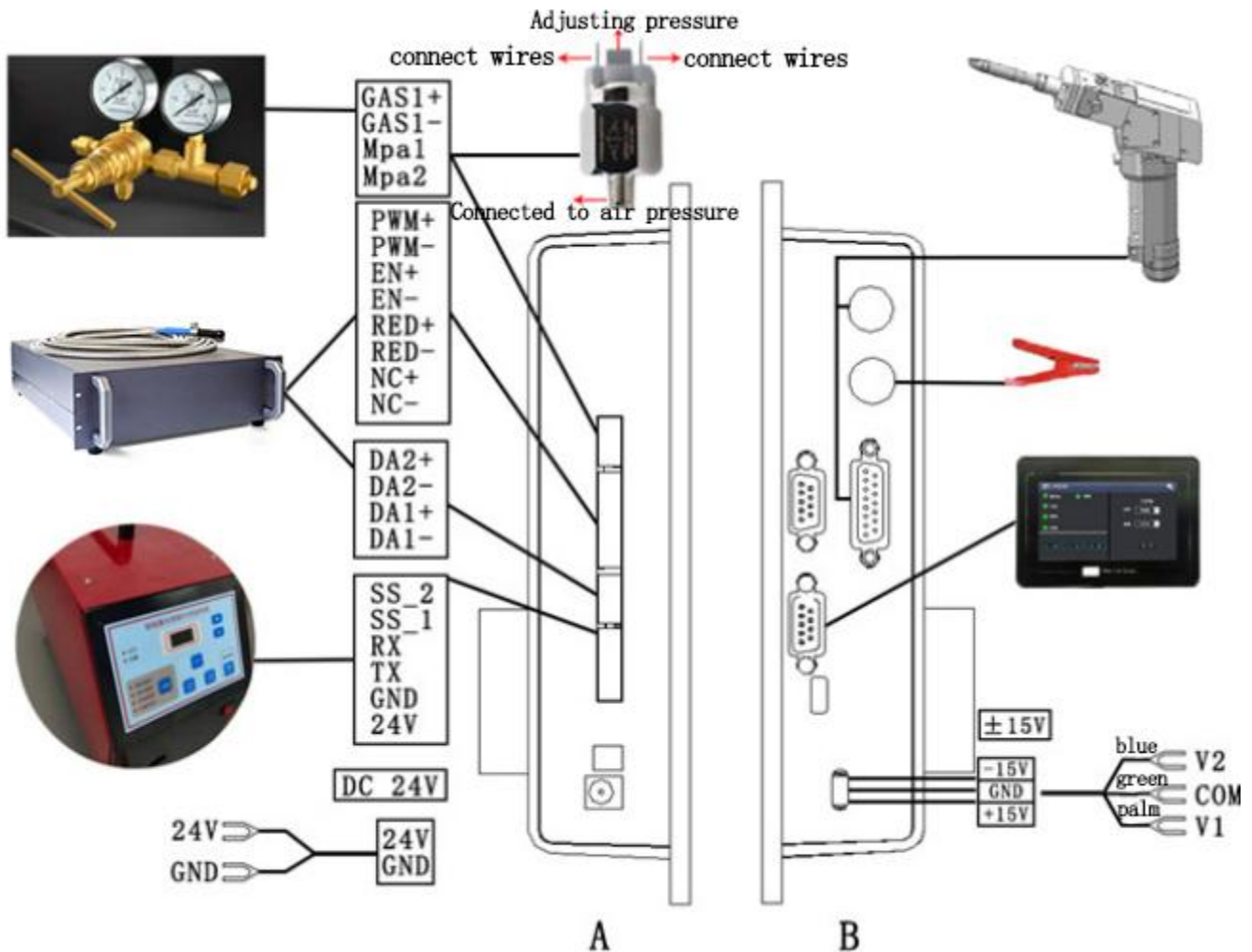
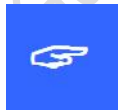

Figure 2.1 Schematic diagram of the system wiring

important:



Do not connect any instructions in the control box to other lines.

2.2 Structural diagram of gun and pipe and water pipe interface

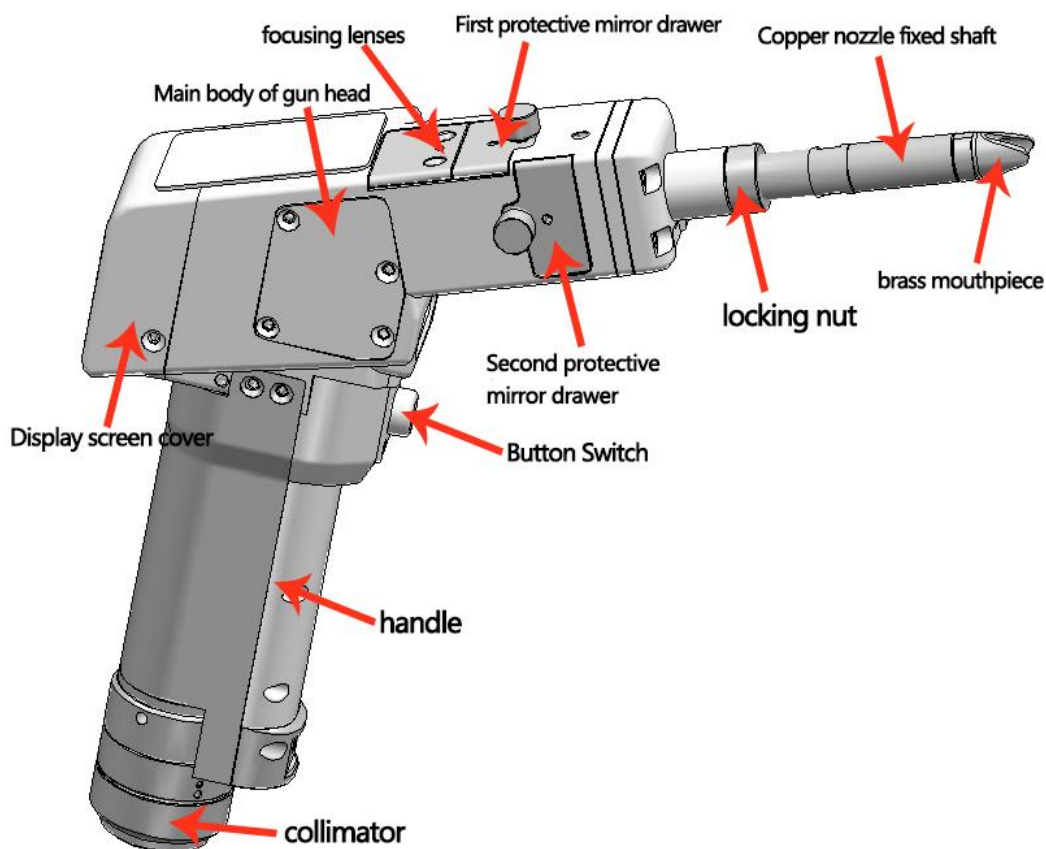

Figure 2.21, a structural diagram of the gun

parameter	scope
interface type	QBH
laser power	2000W
Collar focal length	50
Focus focal length	150
Regulate the spot	Points, line, circle, ellipse, triangle, 8 words,
Adjustable surface	0—5mm
cooling-down method	Water cooling / air cooling
Applicable wavelength	1064-1080nm
Collimine lens	D20F50
Focus on the lens	D20F150
Reflective mirror	22.5×17T3
Protection mirror specifications	D20T2
Maximum air pressure support	0.6Mpa
Focus of vertical adjustment range	±3mm
TBM	0.98KG



Figure 2.22 Schematic diagram of gas pipe and water pipe interface

Water pipe: a water pipe in and out, forming a closed water cycle.

Tracheal: single connector, gas output.

DB15 interface: connect the control system and the gun head communication function.

Samsung Air plug: Connect the conduction and trigger signal connector.

2.3 Power interface



Figure 2.31 Schematic diagram of the Power interface



+ 15V interface is the interface that provides power for the motor drive inside the control box, the voltage is positive or minus 15V ($\pm 15V$)

Table 2.31 defines the $\pm 15V$ interface power cord

Table 2.31

pin	signal	definition	explain
1	V1	Power supply input is positive at 15V	+15 External power input, external power out put The current is greater than 2A
2	COM	Power reference	Power to
3	V2	Power supply input is negative for 15V	-15 External power supply input, external power supply output The current is greater than 2A

The DC24V interface is the interface that provides the power supply for the internal control system of the control box. The DC voltage is 24V (DC24V)

Table 2.32 defines the wiring of the POWER 2 power cord.



Figure 2.32 shows the schematic diagram of the POWER 2 power supply line



Table 2.32 shows the definition of the + 24V interface power line

Table 2.32

pin	signal	definition	explain
1	24V	power input	+ 24V external power supply input, the output power requirements of the power supply: above 200W, that is, the output current is greater than 8A (wire supply for mechanical and electrical demand)
2	COM	Power reference	Power to

2.4 Human-machine interface HMI

The HMI interface is a DB9 black plug through which the motherboard supplies and communicates to the HMI,



Figure 2.4 HMI, schematic diagram

Table 2.4 defines the HMI interface.

Table 2.4

pin	signal	definition	explain
1	24V	Power supply output, 500 mA	HMI supply electricity
2	GND	Power supply output ground	Power reference
3	TXD	The sender of the HMI	Serial port communication with the TXD signal
4	RXD	The receiving end of the HMI	Serial port communication with the RXD signal

2.6 Double swing handheld laser welding head interface

The motherboard provides a vibrating scope interface, compatible with the common digital lens interface on the market,

Table 2.6 shows the definition of the vibration scope interface.

Table 2.6

pin	signal	definition	explain
1	DB15	Vibrator scope & OLED interface	Control line for communication with the hand-held welding head

2.7 Lead the trigger line

The control box provides a special security trigger signal line interface, which can provide a security guarantee for the operation.

Table 2.7 shows the definition of the safety clip interface.

Table 2.7

pin	signal	definition	explain
1	CF	trigger signal	The light condition is met when triggered
2	DT	Guide communication number	The light condition are achieved when on

2.8 Introduction of the fan interface

The control box provides a dedicated 24V fan port interface position, independent socket, not easy to insert wrong.



Figure 2.8 Schematic diagram of the fan interface

2.9 Control interface of the wire feeder

The control box provides a special communication interface for the control wire feeder, and the 24V power supply is directly connected to the power input end of the control box and can be provided 3A current, Table 2.9 defines the control interface of the wire feeder.

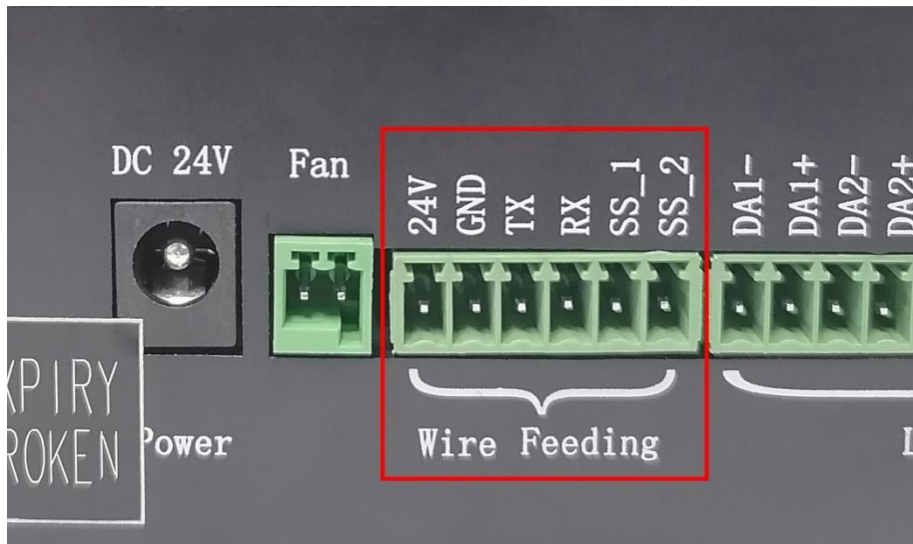

Figure 2.9 Schematic diagram of the control interface of the wire feeder

Table 2.9

pin	signal	definition	explain
1	24V	Power supply output end of wire feeder	Wfeeder 24V + power interface
2	GND	GND	GND
3	TX	Silk feeder and board card communication port	The wire transmitter communicates with the control system on TX signals
4	RX	Silk feeder and board card communication port	The wire feeder communicates the RX signals with the control system
5	SS_1	Wfeeder trigger signal 1	When short circuit SS_1 and SS_2
6	SS_2	Wfeeder trigger signal 2	When short circuit SS_1 and SS_2

2.10 Description of the wire feeder keys

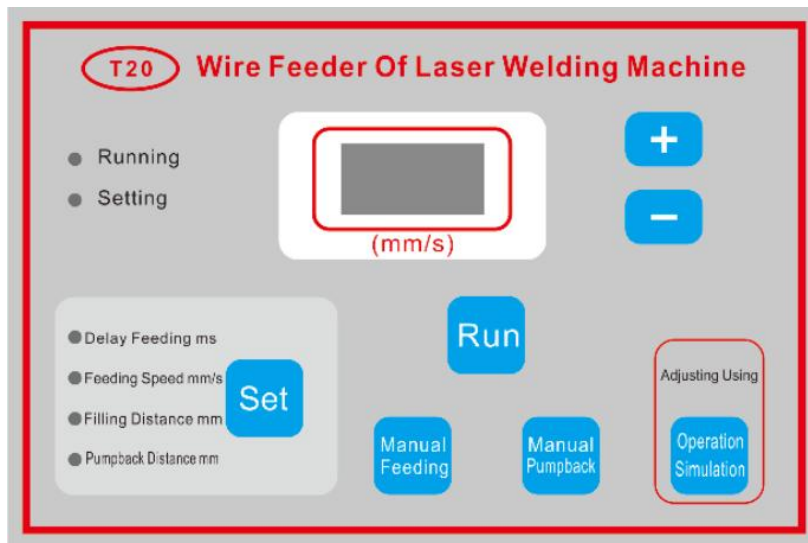

Figure 2.10 Schematic diagram of the control interface of the wire feeder

Filming machine instructions:



: Send wire setting +



: Send wire settings-



: Set wire delay, wire speed, wire filling distance and withdrawal distance.



: Save the parameters after setting the parameters.



: Click the manual wire, and the wire wheel runs the wire at the maximum speed.



: Click manual withdrawal, and the delivery will at the maximum speed.



: After the wire speed is set, click simulation Run is the set wire speed.

Silk delay: after setting, light delay and then wire.

Wire delivery speed: running speed of the wire wheel.

Fililling distance: silk compensation distance after puldrawing stops.

Return distance: after the wire stops, the wire pulls back.

2.11 Laser control interface

The laser interface is an 8 PIN, green terminal + 4 PIN green terminal

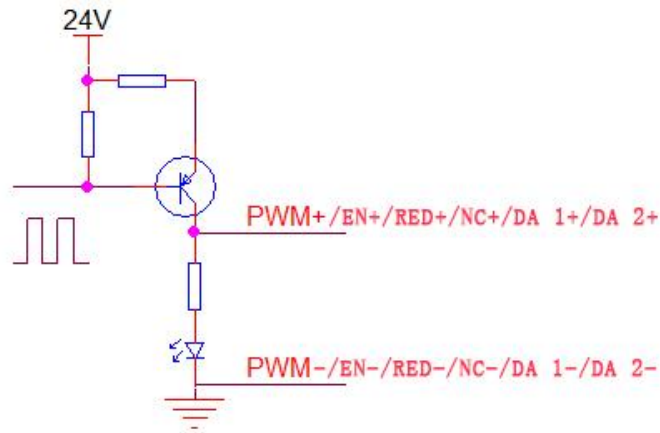

Figure 2.11 Schematic diagram of the laser control interface

Table 2.11 shows the definition of the laser interface.

Table 2.11

pin	signal	definition	explain
1	PWM+	Laser-modulated signal +	Duty cycle 1% -100% adjustable, 24V and 5V switchable
2	PWM-	Laser Modulated signal-	Reference to the power source
3	EN+	Laser enabling signal +	Control laser light signal, high level effective, 24V and 5V can be switched
4	EN-	Laser-enabling signal-	Reference to the power source
5	RED+	Laser red light signal	Laser red light control (optional)
6	RED-	GND	Reference to the power source
7	NC+	The laser enables the backup port	Laser 24V backup port
8	NC-	Laser backup port ground	Reference to the power source
9	DA 1+	Analog voltage output +	For laser peak power regulation, 0-10V and 0-4V analog voltage selection
10	DA 1-	Analog voltage output-	Reference to the power source
11	DA 2+	Analog voltage output	For proportional valve adjustment, 0-10V analog voltage,
12	DA 2-	GND	Reference to the power source

2.10, definition of laser wiring of different manufacturers

control system	Laser models from different manufacturers												
Qilin system	Re ci FSC1000/1500 /2000/3000	Kai pu lin 500T/1000T/ 1500T		Fe bo YDFL-1000-CW		Chuang xin MFSC -1000X/1500X		Rui ke RFL-C-series		Rui ke RFL-C-X/H		Jie pu te kou CTRL- INTERFACE	
PWM+	12.MOD SW IN+	21.PWM+		15.GATE		17.Modulation In +		15.MOD+		15.MOD+		3.modulate+	
PWM-	13.MOD SW	8.PWM-		16.GND IO		4.Modulation In -		16.MOD-		16.MOD-		16.modulate-	
EN+	5.LASER EN+	19.enable+		18.EX-EN		18.enable input+		18.Laser EN		18.Laser EN		4.enable+	
EN-	6.LASER EN-	6.enable-		20.GND IO		5.enable input -		20.EGND		20.EGND		5.enable-/Alarm output-	
DA1+	14.ANG 0~10V+	15.AD+		12.IFWD SET		15.DA (0-10V) input+		12.Analog		12.0-10V		18.0-10V+	
DA1-	15.ANG GND-	14.AD-		14.CASE		2.DA (0-10V) input-		14.AGND		14.AGND		6.0-10V-/Analog input ground	
RED+				17.RED-EN				17.Red Laser					
RED-								23.EVCC		24V		17.EVCC	
										21.AD/RS		24V	
notes		10.interlocking 1+	short circuit	1.INTLK1A	short circuit	19.interlocking+	short circuit	2.Reserve Interlock	short circuit	2.ITL-A	short circuit	8.interlocking 1+	short circuit
		23.interlocking 1-	short circuit	4.INTLK1B	short circuit	6.interlocking-	short circuit	3.Reserve Interlock	short circuit	3.ITL-B	short circuit	21.interlocking 1-	short circuit
		12.interlocking 2+	short circuit	2.INTLK2A	short circuit			8.Reserved remote power on	short circuit	8.RPA	short circuit	9.interlocking 2+	short circuit
		25.interlocking 2-	short circuit	3.INTLK2B	short circuit			9.Reserved remote power on	short circuit	9.RPB	short circuit	22.interlocking 2-	short circuit
								10.Reserved emergency stop	short circuit				
								11.Reserved emergency stop	short circuit				
						Turn the key to ON, wait for the self test to complete and press START after starting the machine						Turn the key on the front panel of the laser to the robot and press start	

Figure 2.10, Defindigram of laser wiring of different manufacturers

2.12 Gas control and air pressure detection interface

The control box provides a dedicated IO interface, all output IO are using OC output can directly drive the relay, the maximum current can reach 500 mA, the wiring diagram is shown below.

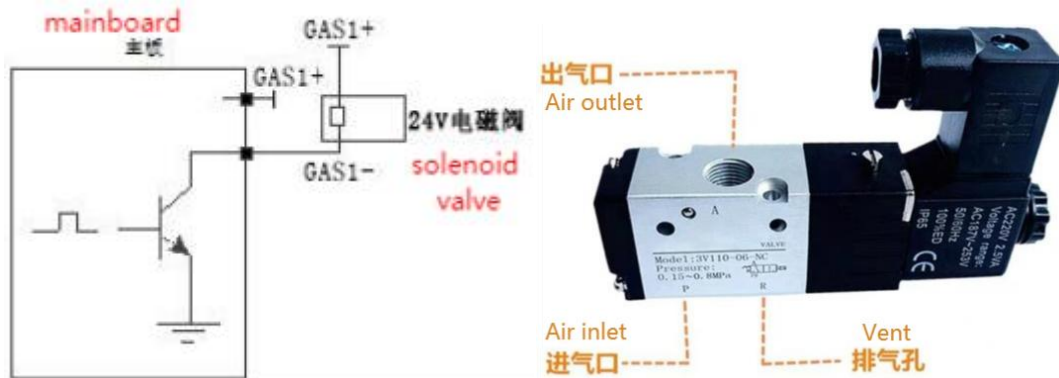

Figure 2.121 Schematic diagram of the gas control interface

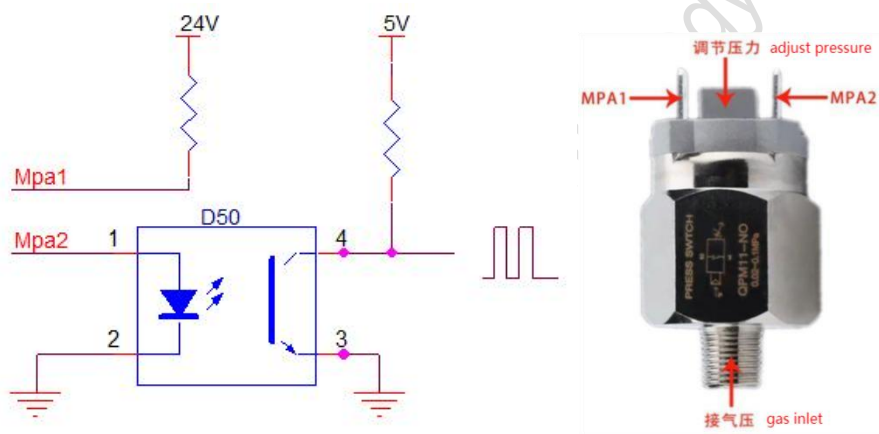

Figure 2.122 Schematic diagram of the air pressure detection interface

Table 2.12 defines the gas control interface

Table 2.12

pin	signal	definition	explain
1	CAS 1+	Used to protect the gas blowing control positive electrode	Air valve + board card GAS 1 +
2	CAS 1-	Used to protect the gas to blow the gas to control the negative electrode	Valve-board card GAS 1-
3	Mpa1	Used to detect the air pressure alarm	Air pressure alarm + connecting plate Mpa 1
4	Mpa2	Used to detect the air pressure alarm	Air pressure alarm + connecting plate Mpa 2

2.13, the dial-code switch



Figure 2.13, schematic diagram of dial switch

order number	characteristic	definition	explain
1	IPG	Laser control signal	PWM, EN, RED, NC output 5V Power adjustment: 0-4V analog voltage adjustable section
2	NO IPG	Laser control signal	PWM, EN, RED, and NC with an output of 24V Power adjustment: analog voltage adjustable section 0-10V

Chapter 3 Human-machine interface

HMI introduction

The main contents of this section are:

- Introduction of the main interface function and operation
- Set up the interface function and operation introduction

3.1 Introduction of HMI function and operation of human-machine interface

3.1.1 Introduction of the function and operation of the main interface

The operating panel of Qilin double swing handheld laser welding system adopts 7-inch configuration capacitive touch screen, which is dignified, generous and easy to operate. The relevant parameters of the laser and laser swing head can be set respectively, and the light mode can be controlled. At the same time, the process parameters stored inside the machine can be selected on the main interface, and at the same time, these art parameters can be adjusted and saved, facilitating the subsequent direct call, and the process package can also be customized.

3.1.2 Set the interface function and operation introduction

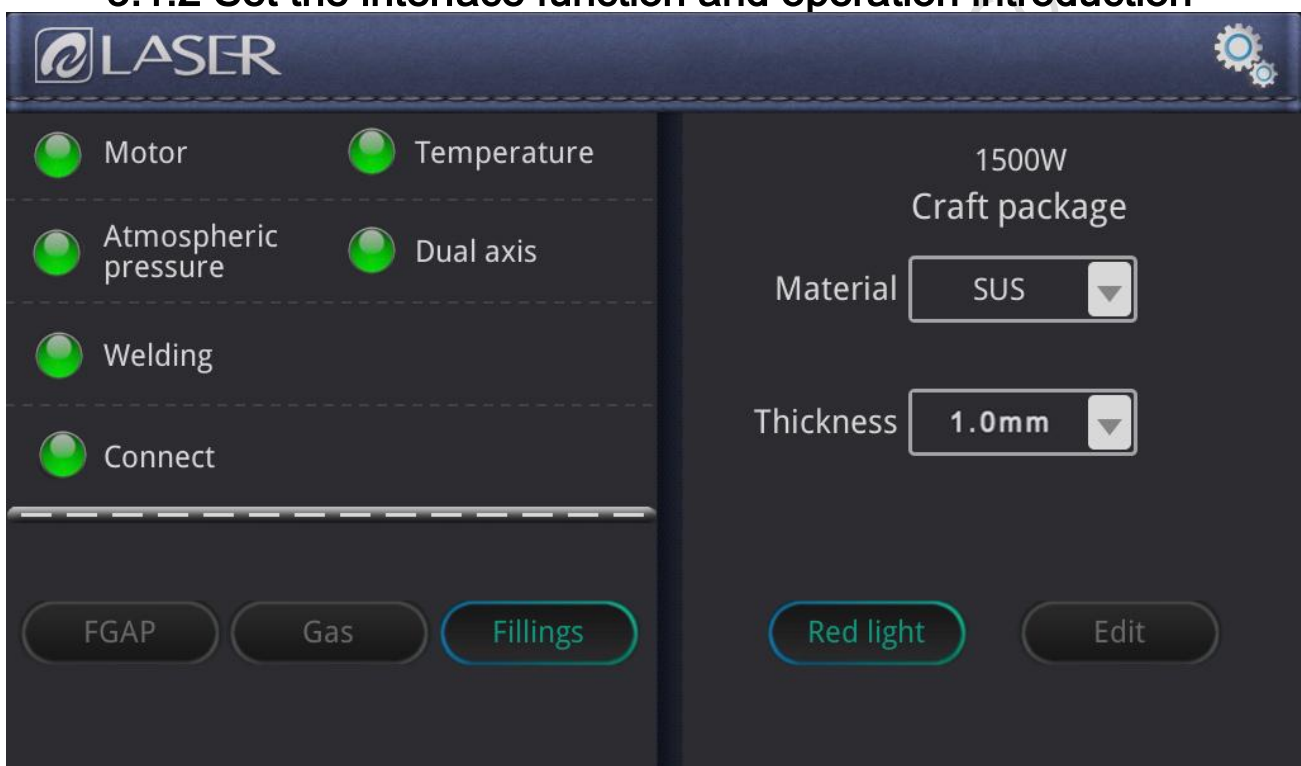

Main interface, schematic diagram

Light lock: the light switch is open to the normal light.

Gas: When the gas opens, the gas valve port will output 24V voltage, and the gas will automatically blow without opening during welding.

Send wire: when the wire is opened, the wire sending opportunity is sent during the light. When the wire is closed, the wire sending machine is not controlled by the welding gun light signal.

Alarm signal light: provide real-time monitoring and reminder, monitor and alarm the temperature of laser head, air pressure, welding torch, conduction and handle. The full alarm state is displayed synchronously on the main screen and alarm light to remind users and quickly check problems.

Process package: The process package has four common materials, and the thickness and parameters corresponding to "custom" and "other" are described as follows:

Stainless steel (SUS): "SUS/1.0mm" means: stainless steel 1.0mm, and so on: "SUS/3.5mm" means: stainless steel 3.5mm

Carbon steel (CS): "CS/1.0mm" means: carbon steel 1.0mm, and so on: "CS/3.5mm" means: carbon steel 3.5mm

Galvanized plate (SECC): "SECC/1.0mm" means: galvanized plate 1.0mm, and so on: "SECC/3.5mm" means: galvanized plate 3.5mm

Aluminum plate (AL): "AL/1.0mm" means: aluminum plate 1.0mm, and so on: "AL/3.5mm" means: aluminum plate 3.5mm

Custom (UDC): can edit parameters, convenient for customers to process for welding at any time.

Other (OTS): internal manufacturer special process editing, special process can be used for special material welding.



Click "  " to enter the main editing interface. After editing parameters, you can save the parameters without clicking confirmation.



Schematic diagram of editing the main interface

Laser control:

Power: Set the peak power of the laser at welding.

PWM frequency: Set the frequency of the laser PWM modulation signal.

Duty cycle: Set the pulse width of the laser PWM modulation signal.

Laser head control:

Mode: Set the motor swing mode.

Seven modes: point, line, circle, ellipse, triangle, figure 8 and semicircle.

Frequency: Set the speed of the motor to swing.

Width: Set the width of the motor to swing.

Out-of-light control:

Mode: Continuous light out mode and pulsed light out mode.

Light time: set the light time.

Light output interval: set, the interval of each light output.

Restore factory Settings: After entering the editing page, restore the single page parameters.



Press the " " in the main interface to enter the setting interface, as shown in the figure below

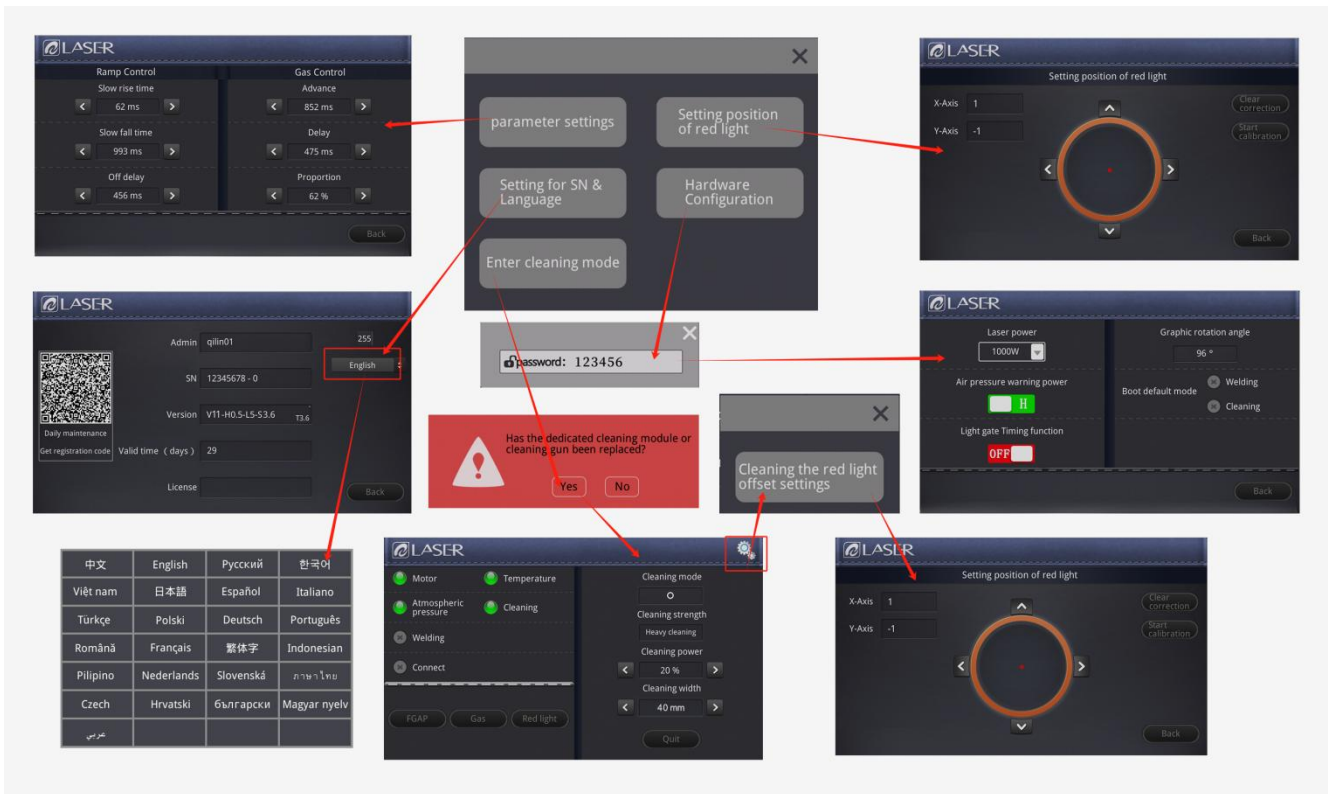

parameter setting:

gas control:

Advance quantity: when starting processing, it can be set.

When the external start button is pressed, the air blow delays for a period of time, and then the laser starts.

Delency: When stopping processing, the delay can be set. When stop processing, stop the laser first, After a time delay, then stop blowing.

Proportional valve: if the equipment is connected to the proportional valve control, the air flow size can be controlled.

Start lift:

Slow rise time: the laser power slowly reaches the peak power after the set slow rise time.

Slow descent time: After the laser power is turned off, the laser energy is slowly turned off.

Light off delay: after closing the laser when set for 100ms, the full power input is 100ms to optimize the wire breaking function.

Red light offset setting:

Red light offset setting: When the red light is not in the center position of the nozzle, it can be adjusted through the red light offset setting position of X and Y coordinates.

Start correction: save the set offset parameters to the system and zero the display coordinates.

Clear correction: Clear the set offset parameters and reset the display coordinates.

SN and language settings:

System SN identification code: Product Serial number.

Firmware version: is the version currently used by the system.

Available period (days): usable period, all functions are invalid after expiration. (Automatic reminder within 7 days)

Registration code: used for decryption. After receiving the registration code, enter and click confirm to decrypt.

Language: English, Russian, Korean, Vietnamese, Japanese, Chinese

"0" in the upper right corner: Click to enter the corresponding LOGO number and replace the LOGO. (It can be repeated before the shutdown, and can not be changed after the shutdown)

Laser unlock code: When the laser is locked, it can be unlocked through this interface. No need to connect the computer to unlock it can directly input the unlock code provided by the laser manufacturer to unlock. (Currently, only chuangxin laser unlocking is supported)

hardware configuration:

Password: 123456.

Laser power: The laser power used can be selected to retrieve the process package of this laser.

Alarm point level conversion: can choose high and low level to remove the laser, chiller and air pressure alarm.

Optical lock timing function: After opening this function, the optical lock will automatically close for 15 minutes without operation. To close this function requires to manually close the optical lock.

Process Package of Reference

Parameters:

order number	1500W laser control				Laser head control		
	Material and thickness	power	frequency	duty cycle	pattern	frequency	width
1	Stainless Steel 1.0	30%	3000HZ	100%	○	10hz	1.6mm
	Stainless Steel 2.0	60%	3000HZ	100%	△	10hz	2.6mm
	Stainless Steel 3.0	90%	3000HZ	100%	⊠	10hz	3mm
2	Carbon steel 1.0	30%	3000HZ	100%	○	10hz	1.6mm
	Carbon steel 2.0	60%	3000HZ	100%	△	10hz	2.6mm
	Carbon steel 3.0	85%	3000HZ	100%	⊠	10hz	3mm
3	Galvanized plate 1.0	35%	3000HZ	100%	○	16hz	1.6mm
	Galvanized plate 2.0	65%	3000HZ	100%	△	16hz	2.6mm
	Galvanized plate 3.0	85%	3000HZ	100%	⊠	16hz	3mm
4	Aluminum plate 1.0	40%	3000HZ	100%	○	10hz	1.6mm
	Aluminum board 2.0	70%	3000HZ	100%	△	8hz	2.6mm
	Aluminum board 3.0	85%	3000HZ	100%	⊠	8hz	3mm
The above parameters are provided for the reference purposes only							

Description: For different lasers, other parameters in the process package parameters remain unchanged, only the power modification, can be set according to this formula:

When selecting 1000W laser: $P(1000W \text{ laser}) = P(1500W \text{ laser}) * (1000 / 1500)$

When selecting 2000W laser: $P(2000W \text{ laser}) = P(1500W \text{ laser}) * (2000 / 1500)$

Use the laser welding system precautions

1. The light double pendulum industrial welding head contains lasers, water cooler, laser welding system and laser welding head. In order to avoid interference, ensure that the argon arc welding machine and related equipment with large interference, and ensure that the safe distance is kept at more than 5 meters. Ensure that the laser welding machine has independent space when conditions permit.
2. In order to reduce equipment leakage or static electricity, ensure the use of light double pendulum industrial welding head equipment.
3. Please repeatedly confirm whether the cable joint is connected and locked normally. After locking, it can be wrapped with insulation tape.
4. Check whether the laser head and the optical fiber are locked and connected. After confirming that it is normal, use the beautiful strip tape to seal and wrap it to ensure that the dust does not enter the laser head cavity.
5. Check whether there is water seepage in the cavity and many waterways in the cavity. Do not loosen the screws without professional training to prevent water droplets from entering the cavity.
6. Check whether the protective lens drawer is normal, ensure that the sealing ring is normal and effective, when replacing the protective lens, ensure that the alcohol wipes the external stains of the laser head, at least 5 times, and ensure that the lens environment is clean and clean before the lens is replaced.
7. The laser head is so complex. To avoid short circuit, stay away from the water source and make sure that no liquid can be sprayed on the laser head.
8. Laser head refuses to use strong wind to blow and clean the laser head, and can only be wiped with alcohol and dust-free cloth.
9. The laser head is installed with a digital motor. When used, it must be put gently to prevent motor failure.
10. When the laser head is not used, please use the system gas blowing air for many times to discharge the dust, and remove the copper nozzle, use the sealing tape to seal, and use the copper nozzle to blow the air more than 2 times before using it.
11. Continuous interruption of power supply will cause damage to the welding control system, if the external wire transmitter, 24V power supply, please provide 200W (power voltage 24V, output current equal to or greater than 8A) above the reliable power supply!
12. The external safety lock is 24V high level, do not short connect with the aviation plug GND shell of the system cable, or do not pay attention to collide with each other when installing, otherwise the short circuit may burn the power supply or the main control board.

Quality assurance description:

The warranty period of this product is 12 months, starting from the date of factory. If the product is faulty during the warranty period, it can be sent back Our company, free maintenance, free of labor costs. All lens categories (e. g. collimated lens, focusing lens, mirror, cover Protection lens, motor lens, etc.), appearance parts (cavity and handle, etc.) and consumables (copper nozzle, stainless steel pipe, and other easy to lose Product) is not in the warranty scope.

All parts of this description, the property rights of the works belong to Guangdong Qilin Laser Technology Co., Ltd. Without the permission of the Company, any unit or individual shall not reprint, copy or distribute the relevant content of this product description, if the content information of this product will be changed without notice.

If you have any comments or suggestions on the product and instructions during use, please call for consultation.

Tel.: 18018735163

Fax: 0755-27999931

Address:Room 901, Building E1, SongshanLake Intelligent Valley,Yanhe North Road No.9, Liaobu Town,Dongguan City,Guangdong China

Thank you for using the products of Guangdong Qilin Laser Technology Co., Ltd.!