

Be sure to read the manual before using the system

- This manual is the user manual of double pendulum high power industrial flexible welding system
- Read the manual carefully first to ensure the correct electrical connection

BWT60-PC

Qilin double pendulum high power industrial flexible welding system user manual
V60 control box + BWT 60-PC welding head



Shenzhen Qilin Laser Application Technology Co., LTD

Address: Second floor, Building 8, Panmao Industrial Zone, Shuimeng Road, Gongming Village, Gongming Street, Guangming New District, Shenzhen

Tel. : 0755-27999931

mail:

address:www.qilinlaser.com

Copyright Statement

Shenzhen Qilin Laser Application Technology Co., LTD. (hereinafter referred to as Qilin Laser) reserves all powers.

Qilin Laser has the patent copyright and intellectual property rights of this product. Without the authorization and permission of Qilin Laser, it shall not directly or indirectly copy, manufacture, process and use the product and its related parts, otherwise Qilin Laser will be investigated for relevant legal liabilities according to law.

Qilin Laser retains the right to modify the documents included in this manual without prior notice, while retaining the right to modify any documents attached to this product.

Users should read this manual carefully when using the products described in this article. Qilin Laser shall not bear the direct, indirect, special, incidental or corresponding losses or liabilities caused by the improper use of this manual or this product. Qilin Laser does not bear the following direct or indirect liabilities or losses:

- User shall improperly use this manual or this product
- The loss caused by the user does not follow the relevant safety operation procedures

The loss caused by natural force makes the machine in the movement dangerous, the user has the responsibility to design an effective error handling and safety protection mechanism in the machine, and Qilin laser has no obligation or responsibility to be responsible for the incidental or corresponding losses caused thereby.

Certification statement

The CE Certification Statement

This product has passed the European Union CE (Communate Europpe) safety, certification, has passed the corresponding conformity assessment procedures and the manufacturer's declaration of conformity, in accordance with the relevant EU directives.

ROHS, the certification statement

This product has been approved by the European Union legislation on restricting the use of certain Hazardous ingredients in electronic and Electrical Equipment (Restriction of Hazardous Substances) safety certification, in accordance with the relevant environmental regulations of the European Union.

FCC Certification statement

This product has been certified by the Federal Communications Commission (Federal Communications Commission) and complies with the relevant safety regulations of American electronic products.

security information

When using the system, please ensure that the operation is correct and safe. Some signs or words will be used to remind you of dangerous matters and some important information.



danger:

Represents a serious danger. In the process of use, if the operation is improper or the use method is wrong, it may lead to serious injury or even death, please users and related personnel do not operate easily, until to ensure that the correct operation method and the correct way of use.



warn:

Indicates that a danger exists. In the process of use, if the operation is improper or the use method is wrong, which may cause injury to the personnel, please do not operate easily, until we ensure that the operation method is correct and the use method is correct.



prudent:

Represents a product potential risk. During use, if the use method is wrong or improper operation, the product or some parts may be damaged. Please users and related personnel do not operate easily until the operation method is correct and the use method is correct before use.

**important:**

Represents an important information to note during the product. Please do not ignore this information, which provides effective operational help.



This label indicates laser radiation, which will generally be affixed to the output laser products. Please, be careful of laser and safety when using such equipment.

Receiving goods, unpacking and inspection

The product uses shock-proof soft packaging. If the package has any external damage marks, please check the damage to the equipment and notify the carrier and the carrier of the damage in written documents.

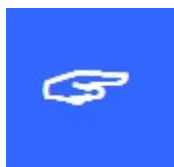

important:

After receiving the product, please check whether the outer package is in good condition, the product and parts after unpacking. If any damage is found, please contact the Qilin Laser immediately.

Remove all the goods from the packaging, and keep the packaging materials and wiring spare parts. When dismantling the package and removing the goods,

Please be careful of the goods for safety. After removing the goods, please check if the parts are complete and intact. If any missing parts or parts are damaged, please contact Qilin Laser immediately. If any obvious damage to the equipment, do not install or debug the equipment.

BWT 60-PC The delivery list of the high power industrial flexible welding system is shown in the following table: (As the product will be updated and upgraded, the delivery list may also be adjusted)

	component	quantity	explain
1	BWT 60 Welding head	1	
2	V 60-PC control box	1	
3	15-inch LCD screen (HMI)	1	
4	15-inch display cable (DB9 head)	1	
5	monitor	1	

6	The 15-inch display screen power cable	1	
7	Plus or minus 15V power supply	1	
8	Plus or minus 15V power cord	1	
9	24V power cord	1	
10	Robot communication line	1	
11	Welding head connecting wire, DB15	1	
12	One point and two DC lines	1	
13	Video line	1	
14	Power extension line	1	
15	Blu-ray light transfer wiring	1	
16	Blu-ray adjustable focus for 12V	1	
17	The DC12V power supply	1	
18	laser goggles	1	
19	Coaxial blowing assembly	1	
20	Spare protective lenses	5	
21	caution light	1	

catalogue

Chapter 1 Overview	8
1.1 BWT 60-PC Qilin double pendulum high power industrial flexible welding system introduction.....	9
1.2 Product installation size drawing.....	9
1.2.1 Touch-screen installation dimensions.....	9
1.2.2 Control box, installation size of the alarm lamp.....	10
1.2.3 15V switch power supply installation size.....	12
Chapter 2. System Wiring	13
2.1 Control box wiring.....	14
2.2 Double-pendulum high-power industrial flexible welding head structure.....	15
2.3 Power joggle.....	17
2.4 human-computer interface HMI.....	19
2.5 Laser-decoding interface.....	19
2.6 Double pendulum industrial welding head interface.....	19
2.7 Urgent stop trigger line.....	19
2.8 Fan interface introduction.....	20
2.9 Control interface of the wire feeder.....	21
2.10 Laser device control interface.....	22
2.11 Gas control, air pressure detection interface.....	23
2.12 Alarm signal interface.....	24
2.13 Robot signal interface	
24.....	
2.14 PNP & NPN conversion plate	
26.....	
2.15 Alarm lamp interface.....	26

2.16 Dial switch.....	27
Chapter 3 HMI Introduction	28
3.1 Human-machine interface function and operation introduction.....	29
Use the laser welding system precautions.....	34

深圳市麒麟激光应用科技有限公司

Chapter 1 summary

**The main contents
of this section are:**

- Double pendulum high
 - power industrial flexible
welding system
- Product installation size
drawing

1.1 Qilin double pendulum high power industrial flexible welding system brief introduction

Qilin double pendulum high power industrial flexible welding system is a control system developed for fiber laser industrial welding and robot cooperation. Up to support 6000W high power output, with a double vibration mirror motor can control seven swing modes: point, line, ring, oval, triangle, eight characters, semicircle. OLED on the welding torch displays the motor operation R signal, supports power slow rise and slow drop, process storage and call, fault alarm indication, a variety of safety protection measures and other functions and features.

1.2 Product installation size drawing

1.2.1 Touch-screen installation dimensions

The installation dimensions of the touch screen are shown below:

15寸

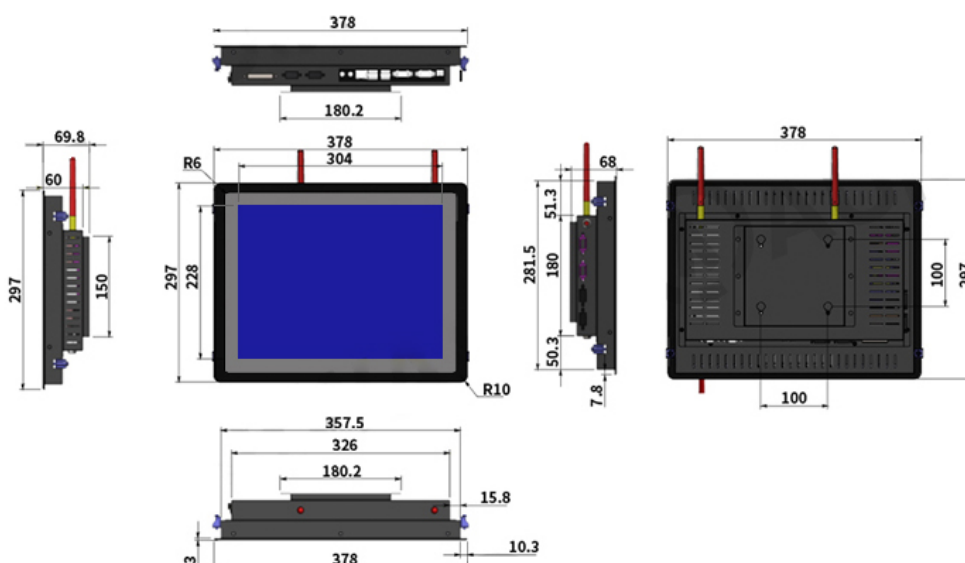

1.2.2 Control box / alarm lamp / torch head mounting size

The installation size of the control box is shown in the following figure

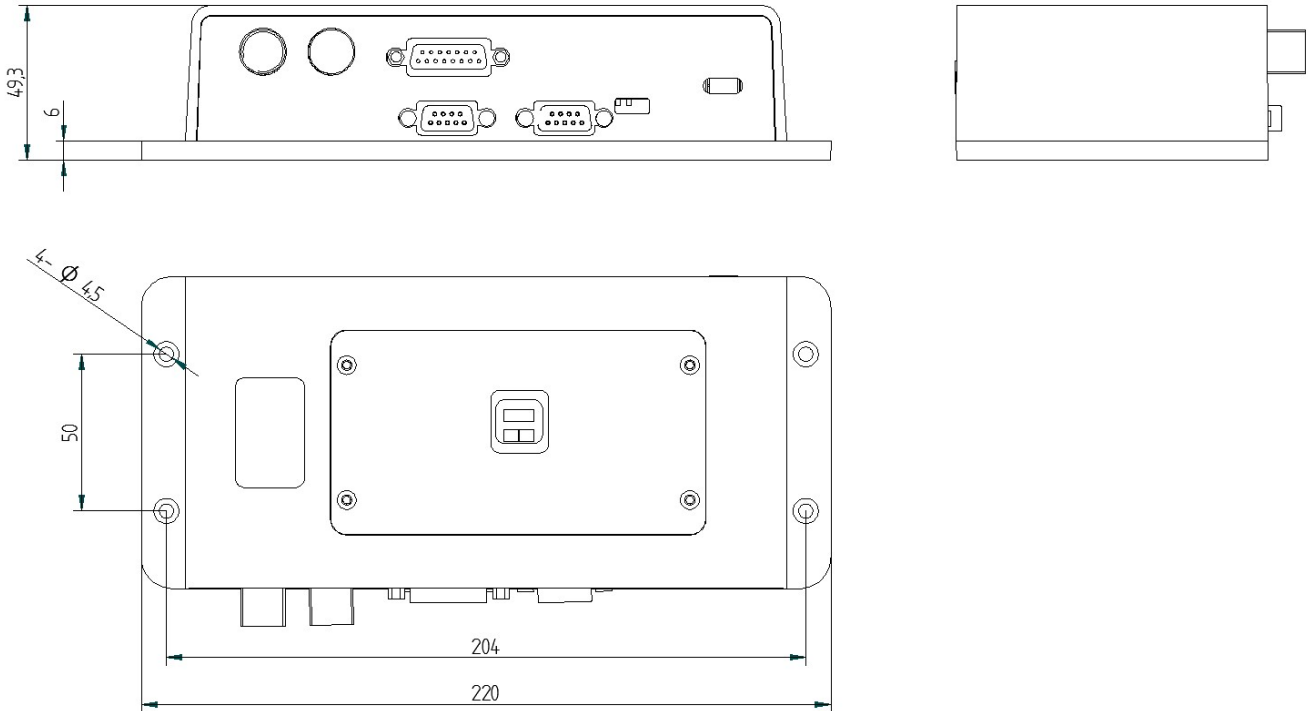

The installation size is shown in the following figure

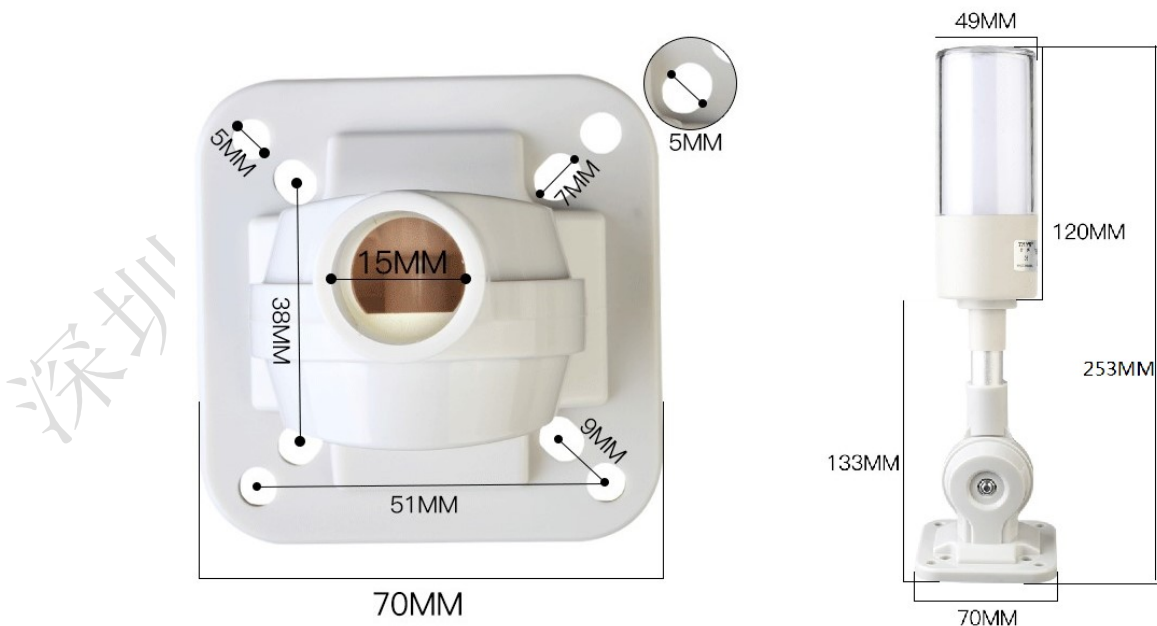

The welding torch head installation size is shown in the figure below

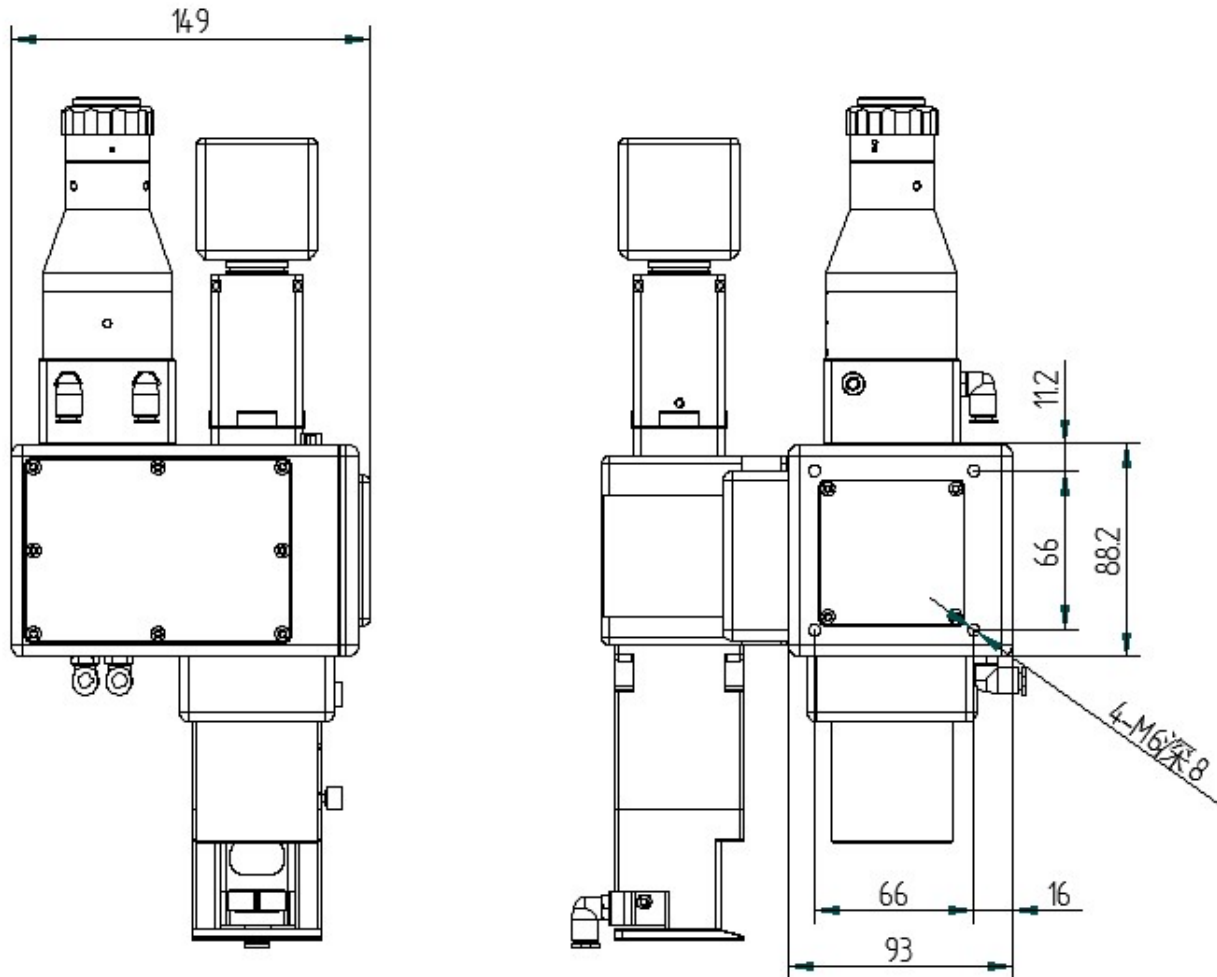

深圳市興...

1.2.3 Installation dimensions of 15 V switching power supply

The installation size of the 15V switching power supply is shown in the following figure



安装尺寸图

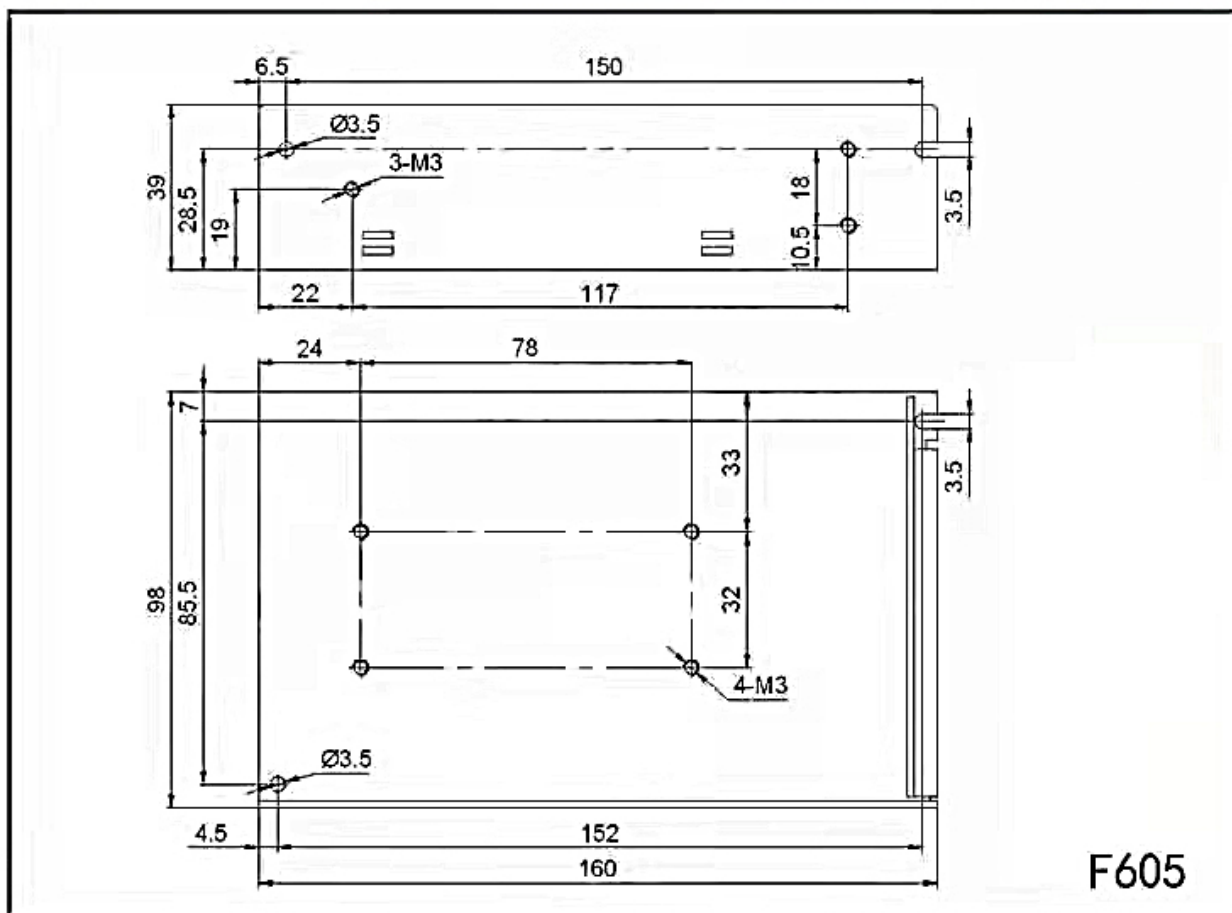

沐

Chapter 2 System wiring

The main contents of this section are:

- Control box
- wiring
- Double pendulum high power industrial flexible welding head structure Power interface
- human-computer interface HMI
- Laser-decoding interface
- Double pendulum industrial welding head interface

- Urgent stop trigger line
- Fan interface introduction
- Control interface of the wire feeder
- Laser device control interface
- Gas control, air pressure detection interface
- Alarm signal interface
- Robot-signal interface
- PNP & NPN conversion board
- Alarm lamp interface
- Dial switch

2.1 Wiring of the control box

The following figure shows the wiring diagram of the whole system. The system wiring can refer to the schematic diagram and refer to the relevant chapter for detailed interface definition.

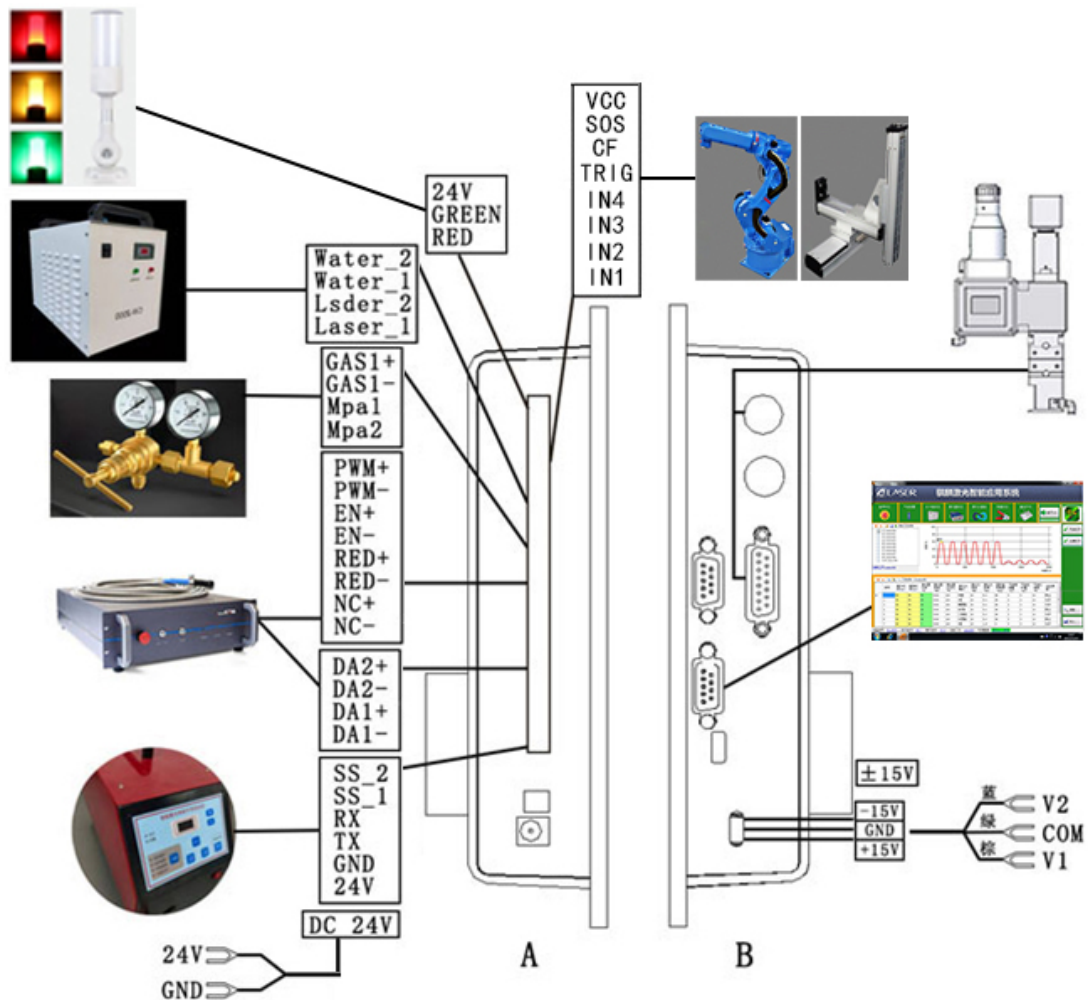
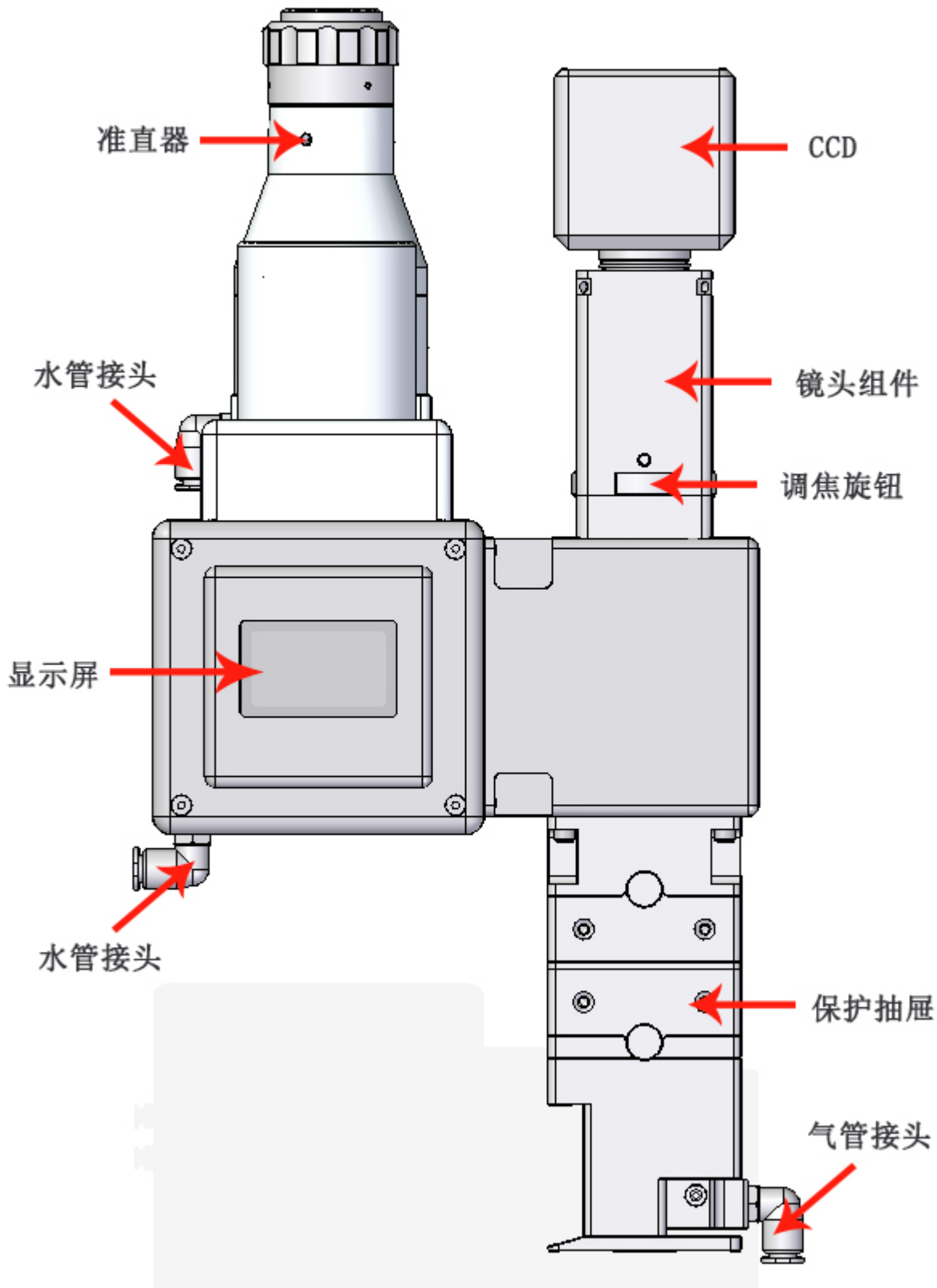

Figure 2.1 Schematic diagram of the system wiring

important:

Do not connect any instructions in the control box to other lines.

2.2 Double pendulum high power industrial flexible welding head structure



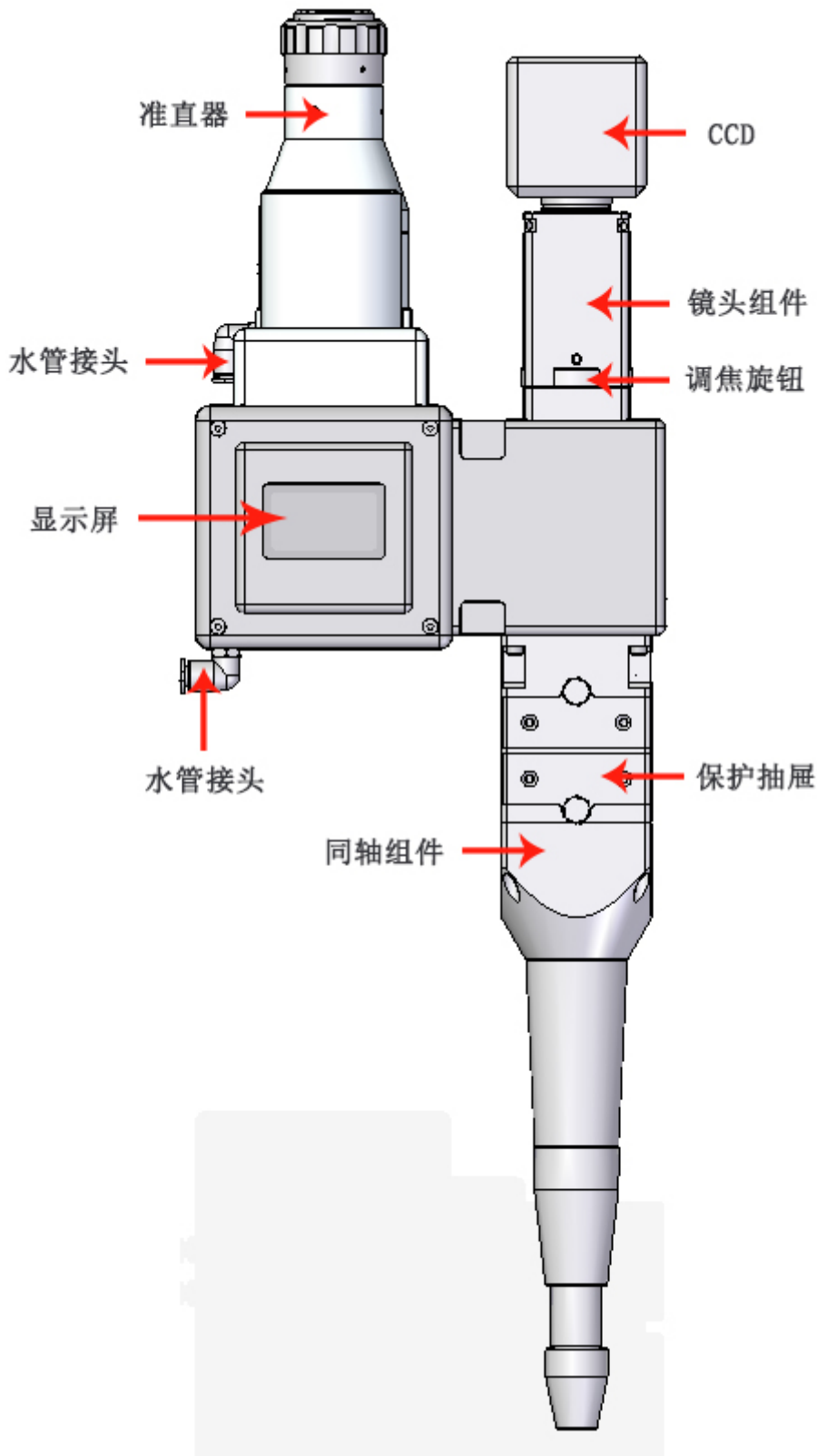

Figure 2.2 Schematic diagram of double pendulum high power industrial flexible welding head structure

parameter	scope
interface type	QBH
laser power	6000W
Collar focal length	100
Focus focal length	300
hunting range	The 0- -5mm is adjustable
cooling-down method	Water cooling / air cooling
Applicable wavelength	1064-1080nm
Collimine lens	D37F100
Focus on the lens	D37F300
Reflective mirror	32×46T3
Protection mirror specifications	D37T5
Maximum air pressure support	0.6Mpa
Focus of vertical adjustment range	±15mm
TBM	6.3KG

2.3 Power interface



Figure 2.31 Power, interface diagram

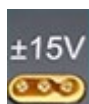

The + 15V interface is the interface that provides the power supply for the motor drive inside the control box. The voltage is plus or minus 15V (+ 15V)

Table 2.31 shows the definition of the + 15V interface power line

Table 2.31

pin	signal	definition	explain
1	V1	Power supply input is positive at 15V	+ 15 External power input, external power output The current is greater than 2A
2	COM	Power reference	Power to
3	V2	Power supply input is negative for 15V	-15 External power supply input, external power supply output The current is greater than 2A

The DC24V interface is the interface for providing the power supply for the internal control system of the control box. The DC voltage is 24V (DC24V)



Figure 2.32 shows the schematic diagram of the POWER 2 power supply line



Table 2.32 shows the definition of the + 24V interface power line

Table 2.32

pin	signal	definition	explain
-----	--------	------------	---------

on			
1	24V	power input	+ 24V external power supply input, the output power requirements of the power supply: above 200W, that is, the output current is greater than 8A (wire supply for mechanical and electrical demand)
2	COM	Power reference	Power to

2.4 Human-machine interface HMI

The HMI interface is a DB9 plug through which the motherboard supplies and communicates to the HMI,



Figure 2.4 Schematic diagram of HMI



Computer side selection control box side



selection.

2.5, the laser decoding interface



LASER RS232 The interface is the board card and the laser communication port.

pin	signal	definition	explain
1	DB 9 (public)	Laser and board card communication interface	Communication with the laser and the decryption function

2.6 Double pendulum industrial welding head interface

The motherboard provides a vibrating scope interface, compatible with the common digital lens interface on the market,

Table 2.6 shows the definition of the vibration scope interface.

Table 2.6

pin	signal	definition	explain
1	DB15	Vibrator scope & OLED interface	Control line for communication with industrial welding heads

2.7 Emergency stop trigger line

The control box provides a special security trigger signal line interface, which can provide a security guarantee for the operation. Table 2.7 defines for the safety clip interface.

Table 2.7

pin	signal	definition	explain
1	CF	trigger signal	Standby port
2	DT	Guide communication number	Standby port

2.8 Introduction of the fan interface

The control box provides a dedicated 24V fan port interface position, independent socket, not easy to insert wrong.



Figure 2.8 Schematic diagram of the fan interface

2.9 Control interface of the wire feeder

The control box provides a special communication interface for the control wire feeder, and the 24V power supply is directly connected to the power input end of the control box and can be provided

^{3A} Current, Table 2.9 defines the control interface of the wire feeder.

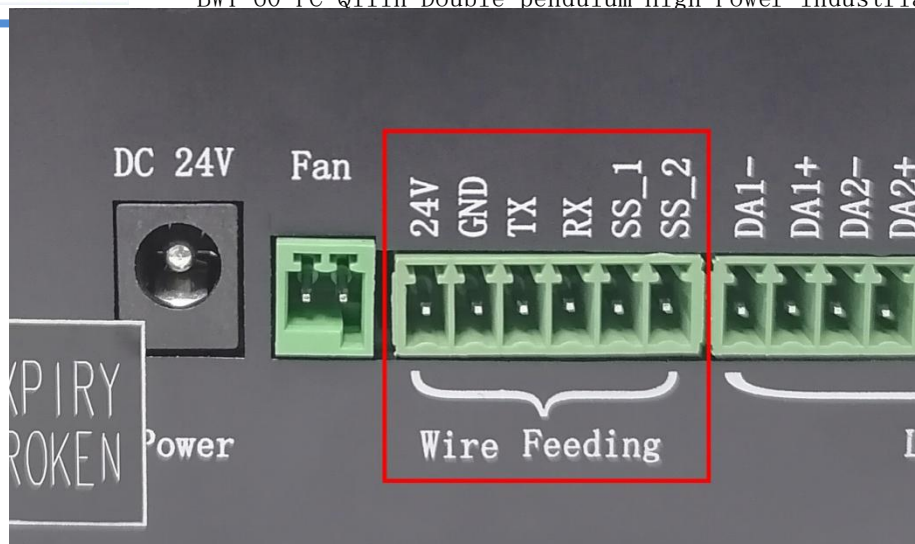

Figure 2.9 Schematic diagram of the control interface of the wire feeder

Table 2.9

pin	signal	definition	explain
1	24V	Power supply output end of wire feeder	Wfeeder 24V + power interface
2	GND	GND	GND
3	TX	Silk feeder and board card communication port	The transmitter communicates with the control system with TX signals
4	RX	Silk feeder and board card communication port	The wire feeder communicates the RX signals with the control system
5	SS_1	Wfeeder trigger signal 1	When short circuit SS_1 and SS_2
6	SS_2	Wfeeder trigger signal 2	When short circuit SS_1 and SS_2

2.10 Laser control interface

The laser interface is an 8 PIN, green terminal + 4 PIN green terminal

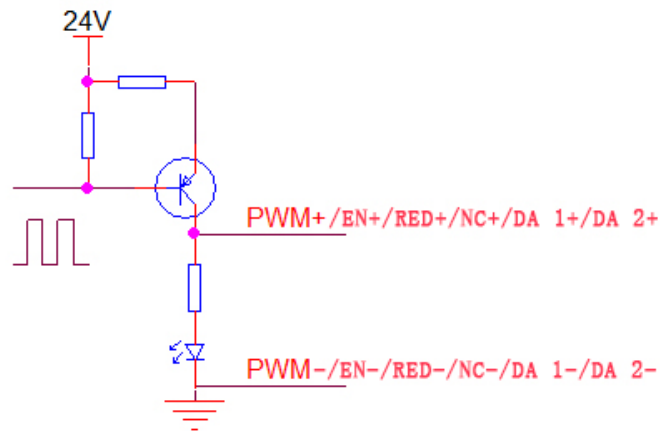

Figure 2.10 Diagram of the laser control interface

Table 2.10 shows the laser interface definition.

Table 2.10

pin	signal	definition	explain
1	PWM+	Laser-modulated signal +	Duty cycle 0% -100% adjustable, 24V and 5V switchable
2	PWM-	Laser Modulated signal-	Reference to the power source
3	EN+	Laser enabling signal +	Control laser light signal, high level effective, 24V and 5V can be switched
4	EN-	Laser-enabling signal-	Reference to the power source
5	RED+	Laser red light signal	Laser red light control (optional)
6	RED-	GND	Reference to the power source
7	NC+	The laser enables the backup port	Laser 24V backup port
8	NC-	Laser backup port ground	Reference to the power source
9	DA 1+	Analog voltage output +	For laser peak power regulation, 0-10V and 0-4V analog voltage selection
10	DA 1-	Analog voltage output-	Reference to the power source

11	DA 2+	Analog voltage output	For proportional valve adjustment, 0-10V analog voltage,
12	DA 2-	GND	Reference to the power source

2.10, definition of laser wiring of different manufacturers

控制系统	不同厂家激光器型号												
麒麟系统	热刺 FSC1000/1500/2000/3000	凯普林 500T/1000T/1500T	飞博YDFL-1000-CW	创新MFSC - 1000X/1500X	锐科RFL-C系	锐科RFL-C-X/H	杰普特口 CTRL-INTERFACE						
PWM+	12. MOD SW IN+	21. PWM+	15. GATE	17. 调制输入 +	15. MOD+	15. MOD+	3. 调制+						
PWM-	13. MOD SW IN-	8. PWM-	16. GND IO	4. 调制输入 -	16. MOD-	16. MOD-	16. 调制-						
EN+	5. LASER EN+	19. 使能+	18. EX-EN	18. 使能输入 +	18. Laser EN	18. Laser EN	4. 使能+						
EN-	6. LASER EN-	6. 使能-	20. GND IO	5. 使能输入 -	20. EGND	20. EGND	5. 使能-/报警输出-						
DA1+	14. ANG 0~10V+	15. AD+	12. IFWD SET	15. DA (0-10V) 输入+	12. Analog	12. 0-10V	18. 0-10V+						
DA1-	15. ANG GND-	14. AD-	14. CASE	2. DA (0-10V) 输入-	14. AGND	14. AGND	6. 0-10V-/模拟输入地						
RED+			17. RED-EN		17. Red Laser								
RED-													
备注					23. EVCC	24V	17. EVCC	24V					
							21. AD/RS	24V					
		10. 互锁	短接	1. INTLK1A	短接	19. 互锁+	短接	2. 预留Interlock	短接	2. ITL-A	短接	8. 互锁 1+	短接
		23. 互锁	短接	4. INTLK1B	短接	6. 互锁-	短接	3. 预留Interlock	短接	3. ITL-B	短接	21. 互锁 1-	短接
		12. 互锁	短接	2. INTLK2A	短接			8. 预留远程上电	短接	8. RPA	短接	9. 互锁 2+	短接
		25. 互锁	短接	3. INTLK2B	短接			9. 预留远程上电	短接	9. RPB	短接	22. 互锁 2-	短接
								10. 预留急停	短接				
							11. 预留急停	短接					
											激光器前面板钥匙拧到robot后按下start即可		

Figure 2.10, Definition of laser wiring of different manufacturers

2.11 Gas control and air pressure detection interface

The control box provides a dedicated IO interface, all output IO are using OC output can directly drive the relay, the maximum current can reach

500 mA, the wiring diagram is shown below.

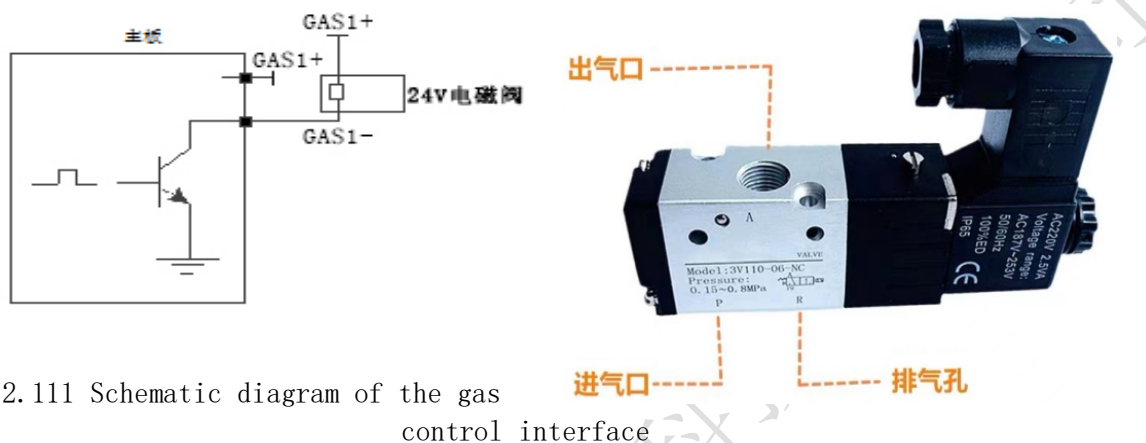

Figure 2.111 Schematic diagram of the gas control interface

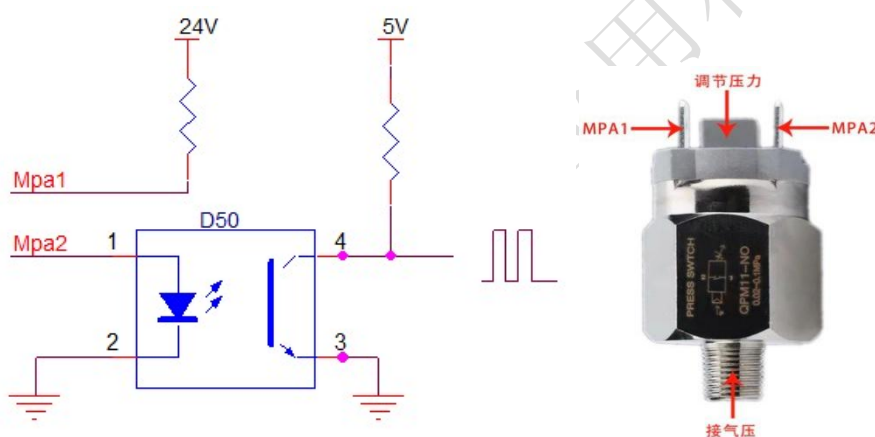

Fig. 2.112 Diagram of pressure detection interface

Table 2.11 defines the gas control interface

Table 2.11

pin	signal	definition	explain
1	CAS 1+	Used to protect the gas blowing control positive electrode	Air valve + board card GAS 1 +
2	CAS 1-	Used to protect the gas to blow the gas to control the negative electrode	Valvalve-board card GAS 1-
3	Mpa1	Used to detect the air pressure alarm	Air pressure alarm + connecting plate Mpa 1

4	Mpa2	Used to detect the air pressure alarm	Air pressure alarm + connecting plate Mpa 2
---	------	---------------------------------------	---

2.12 Alarm signal interface

Laser1 And 2 are the laser alarm signal interface, not on the green light, on the red light.

Water1 And 2 are the alarm signal interface of the chiller, without red light.

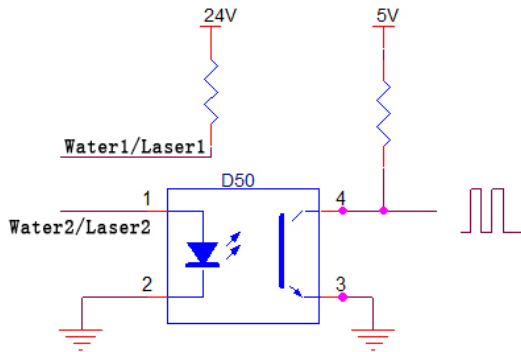

Fig. 2.12 Schematic diagram of the alarm signal interface

Table 2.12 shows the definition of the alarm signal interface.

Table 2.12

pin	signal	definition	explain
1	Laser_1	Laser device alarm signal	Short contact during the laser alarm
2	Laser_2	GND	Laser alarm signal ground
3	Water_1	Chiller machine alarm signal	When the chiller alarms, open and break
4	Water_2	GND	Cold water machine alarm

2.13 Robot signal interface

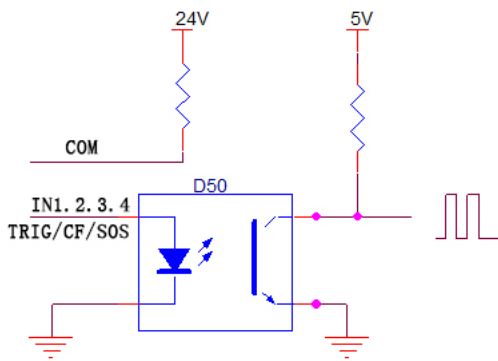

Figure 2.131 Schematic diagram of the robot signal interface

pin	signal	definition	explain
1	IN1	External communication port 1	Read the robot parameter signal
2	IN2	External communication port 2	Read the robot parameter signal
3	IN3	External communication port 3	Read the robot parameter signal
4	IN4	External communication port 4	Read the robot parameter signal
5	TRIG	Laser slow drop advance signal	Read the laser slow-up signal
6	CF	The robot will trigger the signal	When CF and COM short circuit, light out (if other conditions are reached)
7	SOS	Robot emergency stop signal	Emergency stop signal input can be set to NC and NO
8	VCC	Shared end	common port.

Communication I / O status: IN 1, IN 2, IN 3, IN 4 multistation communication port, through the combination of these terminals, to select the corresponding serial number process (such as IN 1 = 1, namely IN 1 and VCC short circuit), such as:

IN 4 = 0, IN 3 = 0, IN 2 = 0, IN 1 = 0, corresponding to the process

parameters of the 0th serial number,

IN 4 = 0, IN 3 = 0, IN 2 = 0, IN 1 = 1, corresponding to the process parameters of the first serial number,

IN 4 = 0, IN 3 = 0, IN 2 = 1, IN 1 = 0, corresponding to the process parameters of the second serial number,

IN 4 = 0, IN 3 = 0, IN 2 = 1, IN 1 = 1, corresponding to the process parameters of the third serial number,

IN 4 = 0, IN 3 = 1, IN 2 = 0, IN 1 = 0, corresponding to the process parameters of the fourth serial number,

IN 4 = 0, IN 3 = 1, IN 2 = 0, IN 1 = 1, corresponding to the process parameters of the fifth serial number,

IN 4 = 0, IN 3 = 1, IN 2 = 1, IN 1 = 0, corresponding to the parameters of the 6th process number,

IN 4 = 0, IN 3 = 1, IN 2 = 1, IN 1 = 1, corresponding to the process parameters of the seventh serial number,

IN 4 = 1, IN 3 = 0, IN 2 = 0, IN 1 = 0, corresponding to the process parameters of the 8th serial number,

IN 4 = 1, IN 3 = 0, IN 2 = 0, IN 1 = 1, corresponding to the process parameters of the ninth serial number.

TRIG multiple station slow drop notification signal, TRIG = 1 (TRIG and VCC short circuit), slow drop start.

The process package parameters are selected by high and low electrical frequency, and binary programming is used to select the corresponding process 0-9.

2.14 PNP & NPN conversion board

Each robot output interface on the market is different, usually divided into solid state relay, PNP and NPN output. This conversion board has input terminal robot (ROBOOT) (applicable to PNP and PNP), and output terminal control box (CONTROL BOX). The wiring diagram is as follows:

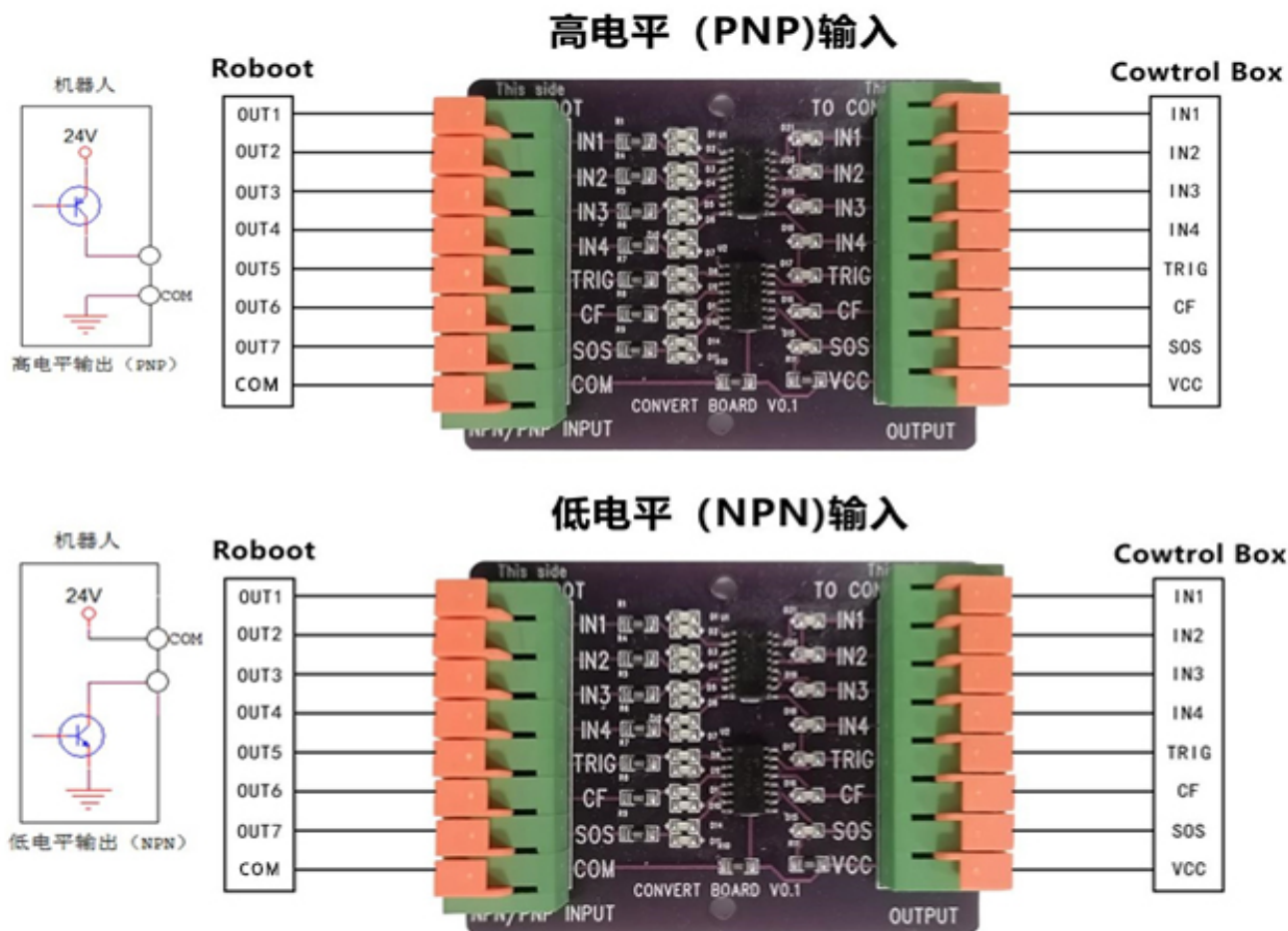

Figure 2.14 Schematic diagram of PNP & NPN conversion board

2.15, alarm light interface

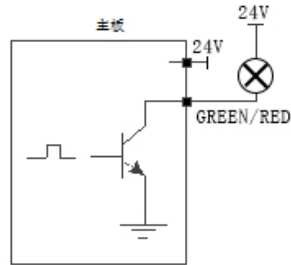

Figure 2.15 Schematic diagram of the alarm lamp interface

When the RED has voltage, the alarm light is red.

When the alarm is removed, the GREEN has a voltage, and the alarm light is green.

Table 2.14 is the definition of the alarm signal light.

pin	signal	definition	explain
1	24V	Power supply output end of the alarm signal lamp	Connect to the power supply terminal of the alarm signal lamp
2	GREEN	Alarm signal light-green light	Connect the alarm signal light
3	RED	Alarm signal light-red light	Connect the alarm signal light red

2.16, the dial-code switch

order number	characteristic	definition	explain
1	IPG	Laser control signal	PWM, EN, RED, NC output of 5V Power adjustment: 0-4V analog voltage adjustable section
2	NO IPG	Laser control signal	PWM, EN, RED, NC output of 24V Power adjustment: analog voltage adjustable section 0-10V

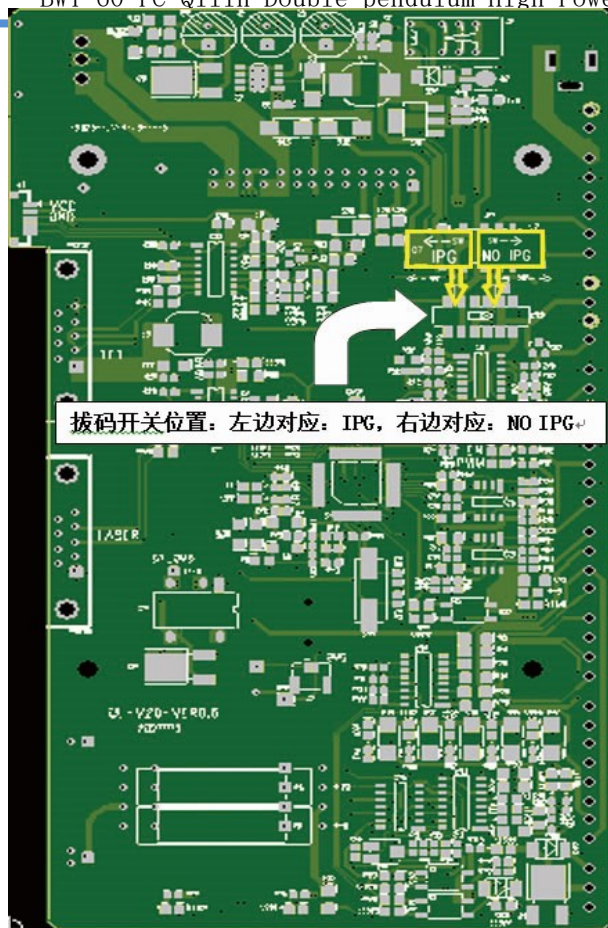

Figure 2.16, schematic diagram of dial switch

Chapter 3 Human-machine

interface HMI introduction

The main contents of this section are:

- Human-machine interface function and operation introduction

3.1 Introduction of human-machine interface function and operation

Introduction of the main interface function and operation

The operating panel of Qilin double pendulum high power industrial flexible welding system adopts 15-inch configuration capacitive touch screen, which is dignified, generous and easy to operate. Can set the laser, laser swing head related parameters, can also control the light mode, at the same time can select the machine inside the main interface storage process parameters, while the adjusted art parameters, convenient subsequent direct call, also can customize the art package and can be obtained in the welding process of various welding mode.



3.1. Schematic diagram of the main interface 1

Operation and use:



Open the Qilin laser multi-station control system, click select to set the communication parameter setting, select the serial port 1, port rate 115200, click confirm. After selecting the communication parameters, then power the control board and enter the multistation control system.



system.

序号	缓升时间(ms)	缓降时间(ms)	激光器功率(%)	激光器频率(HZ)	激光器占空比(%)	激光头模式	激光头频率(HZ)	激光头宽度(mm)	图形旋转角度(deg)	气体提前量(ms)	气体延时量(ms)	气体比例阀(%)	送丝使能
1	50	50	60	3000	100	线型	20	5.0	90	0	0	10	禁止
2	50	50	60	3000	100	0型	20	5.0	90	0	0	10	允许
3	50	50	60	3000	100	椭圆型	20	5.0	90	0	0	10	允许
4	50	50	60	3000	100	8字型	20	5.0	90	0	0	10	禁止
5	50	50	60	3000	100	三角型	20	5.0	90	0	0	10	允许
6	50	50	60	3000	100	半圆型	20	5.0	90	0	0	10	禁止
7	50	50	7	3000	100	0型	20	1.6	0	0	0	10	允许

3.1 Schematic diagram of the main interface 2

Slow-lift control:

Slow ward rise time: power slow rise time can be set

Slow drop time: the power slow drop time can be set

Laser control:

Power: percent adjustable

Frequency: 50 Hz ~ 30,000 Hz

Duty cycle: percentage adjustable

Laser head control:

Mode: The 7 light spot modes are optional

Frequency: 2~30Hz (1Hz=10 pcs / S)

Width: 0.2~5mm adjustable optical spot

angle of rotation:

Graph rotation angle: the welding mode can arbitrarily rotate 360° angle for omnidirectional welding.

gas control:

Advance amount: body blowing time (recommended 150ms)

Time amount: gas delay blowing time (recommended 200ms)

Proportional valve: The percentage control is valid when installing proportional valves.

Silk sending enabling: can be set to make any welded wire segments have the wire sending function.

Emergency stop state: the robot emergency stop alarm signal.

Gas alarm: the gas pressure is insufficient, and the alarm signal light is on.

Water cooling box state: refers to the working state of the water cooling box, showing red when the water cooling box is abnormal.

Laser state: refers to the working state of the laser, showing red when the laser is abnormal.

Laser head communication: refers to the laser head communication state, laser head communication abnormal or abnormal motor display red.

On state: in the hand-held welding gun mode, the gun head contacts the metal plate with the crocodile clip. When the safety signal is abnormal, the safety signal is shown as red, and the other two modes are always on, showing green.

Trigger switch: When the robot gives the output signal to the board card, the trigger switch has the green light.

Gas: The blowing signal is effective when the manual test light is on (please close the gas

button for automatic welding).

Light lock: control of the laser light signal (the light lock button automatically closes after 15 minutes without operation).

Read out: Read out the selected process package parameters.

Write: Save the function after changing the process parameters.



3.1. Schematic diagram of the main interface 3

Red light offset setting: adjust the X and Y axis coordinate keys, change the Angle of the motor mirror, let the red light offset relative position. The laser center point adjustment radius is 5mm. Ensure that all motor lines are normal before adjustment, and the motor has no E signal alarm to avoid errors.

Communication I / O status: IN 1, IN 2, IN 3, IN 4 multistation communication port; TRIG slow notification signal, TRIG = 1 (TRIG and VCC short circuit), slow drop start.

Device activation:

SN code: the SN verification code when the product leaves the factory.

Available days: days of use of the product, requiring decryption after expiration.

Registration code: after receiving the password, enter the registration code and unlock the password.

Process Package of Reference Parameters:

order number	1500W laser control				Laser head control		
	Material and thickness	power	frequency	duty cycle	pattern	frequency	width
1	Stainless Steel 1.0	30%	3000HZ	100%	○	10hz	1.6mm
	Stainless Steel 2.0	60%	3000HZ	100%	△	10hz	2.6mm
	Stainless Steel 3.0	90%	3000HZ	100%	□	10hz	3mm
2	Carbon steel 1.0	30%	3000HZ	100%	○	10hz	1.6mm
	Carbon steel 2.0	60%	3000HZ	100%	△	10hz	2.6mm
	Carbon steel 3.0	85%	3000HZ	100%	□	10hz	3mm
3	Galvanized plate 1.0	35%	3000HZ	100%	○	16hz	1.6mm
	Galvanized plate 2.0	65%	3000HZ	100%	△	16hz	2.6mm
	Galvanized plate 3.0	85%	3000HZ	100%	□	16hz	3mm

4	Aluminum plate 1.0	40%	3000HZ	100%	○	10hz	1.6mm
	Aluminum board 2.0	70%	3000HZ	100%	△	8hz	2.6mm
	Aluminum board 3.0	85%	3000HZ	100%	□	8hz	3mm
The above parameters are provided for your reference only							

Description: For different lasers, the other sets of the process package parameters remain unchanged, and only the power is modified, which can be set according to this formula:

When selecting 1000W laser: $P(1000W \text{ laser}) = P(1500W \text{ laser}) * (1000 / 1500)$

When selecting 2000W laser: $P(2000W \text{ laser}) = P(1500W \text{ laser}) * (2000 / 1500)$

Use the laser welding system precautions

1. The light double pendulum industrial welding head contains lasers, water cooler, laser welding system and laser welding head. In order to avoid interference, ensure that the argon arc welding machine and related equipment with large interference, and ensure that the safe distance is kept at more than 5 meters. Ensure that the laser welding machine has independent space when conditions permit.
2. In order to reduce equipment leakage or static electricity, ensure the use of light double pendulum industrial welding head equipment.
3. Please repeatedly confirm whether the cable joint is connected and locked normally.

After locking, it can be wrapped with insulation tape.

4. Check whether the laser head and the optical fiber are locked and connected. After confirming that they are normal, the beautiful strip tape can be sealed and wound to ensure that the dust does not enter the laser head cavity.
5. Check whether there is water seepage in the cavity and many waterways in the cavity. Do not loosen the screws without professional training to prevent water droplets from entering the cavity.
6. Check whether the protective lens drawer is normal, ensure that the sealing ring is normal and effective, when replacing the protective lens, ensure that the alcohol wipes the external stains of the laser head, at least 5 times, and ensure that the lens environment is clean and clean before the lens is replaced.
7. The laser head is so complex. To avoid short circuit, stay away from the water source and make sure that no liquid can be sprayed on the laser head.
8. Laser head refuses to use strong wind to blow and clean the laser head, and can only be wiped with alcohol and dust-free cloth.
9. The laser head is installed with a digital motor. When used, it must be put gently to prevent motor failure.
10. When the laser head is not used, please use the system gas blowing air for many times to discharge the dust, and remove the copper nozzle, use the sealing tape to seal, and use the copper nozzle to blow the air for more than 2 times before using it.
11. Continuous interruption of power supply will cause damage to the welding control system, if the external wire transmitter, 24V power supply, please provide 200W

(power voltage 24V, output current is equal to or greater than 8A) above the reliable power supply!

12. The external safety lock is 24V high level, do not short connect with the aviation plug GND shell of the system cable, or do not pay attention to collide with each other when installing, otherwise the short circuit may burn the power supply or the main control board.

Quality assurance description:

The warranty period of this product is 12 months, starting from the date of factory. If the product is faulty during the warranty period, it can be sent back

Our company, free maintenance, free of labor costs. All lens categories (e. g. collimated lens, focusing lens, mirror, cover

Protection lens, motor lens, etc.), appearance parts (cavity and handle, etc.) and consumables (copper nozzle, stainless steel pipe, and other easy to lose

Product) is not in the warranty scope.

All parts of this description, the property right of the book belongs to Shenzhen Qilin Laser Application Technology Co., LTD. Without the permission of the Company, any unit or individual shall not reprint, copy or spread the relevant content of this product description, if the content and information of this product will be changed without notice.

If you have any comments or suggestions on the product and instructions during use, please call for consultation.

Tel. : 18018735163



Fax: 0755-27999931

Address: Building 8, Fanmao Industrial Zone, Shuiyin Road,
Shanghai Village, Gongming Street, Guangming District, Shenzhen
City

Thank you for using the products of Shenzhen Qilin Laser Application
Technology Co., LTD. !

深圳市麒麟激光应用科技有限公司